



**BEST IN GAMES, SAUNAS,  
POOL AND PATIO**

# **BADDAH BING**

**54" BUMPER POOL TABLE WITH ACCESSORIES - OAK  
RB5800**



**FREETIME FUN  
1830 E. FABYAN PKWY.  
BATAVIA, IL 60510  
WWW.FREETIMEFUN.COM**

**Check all packaging before discarding.**

**Be sure all parts identified in the assembly manual  
are included.**

**Don't assemble if parts are missing.**

**If you are missing parts or have questions please  
contact our toll free line at 1-888-620-6088.**

Thank you for purchasing this product. If you experience any issues during assembly or use of this product, please don't hesitate to contact Customer Service at **1-888-620-6088** for immediate assistance.

## ASSEMBLY TIPS





**IMPORTANT! PLEASE READ THESE ASSEMBLY INSTRUCTIONS IN ENTIRETY BEFORE ASSEMBLING YOUR PRODUCT.**

**Estimated Assembly Time: 45 minutes.**

1. Find a clean, level surface to begin the assembly of your game table. Assembly will require two adults. You may want to carefully cut the four corners of the box so that the bottom of the box can be used as your work surface.
2. Remove all of the contents from the box and verify that you have all of the parts shown on the Parts List before you begin assembly. **Note: Some parts are pre-installed or pre-assembled.**
3. **When installing parts that have more than one screw or bolt, hand tighten all screws or bolts in place before final tightening with screwdriver or wrench.**
4. Electric screwdrivers may be helpful during assembly; however, please set a low torque and use extreme caution because screws may be stripped if overtightened, resulting in damaged parts.

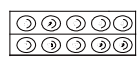



► **THIS PRODUCT IS INTENDED FOR INDOOR USE ONLY.  
DO NOT DRAG THE TABLE WHEN MOVING IT AS THIS MAY CAUSE DAMAGE TO THE LEGS.**

## ACCESSORIES

<p><b>8</b></p>  <p>Bumper Pool Ball Set XRB14507 (1)</p>	<p><b>9</b></p>  <p>Cue Chalk XRB17022 (2)</p>	<p><b>10</b></p>  <p>48" Cue Stick XRB17023 (2)</p>	<p><b>11</b></p>  <p>9" Table Brush XRB12057 (1)</p>
--	---	--	--

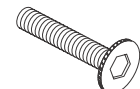
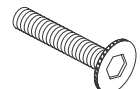
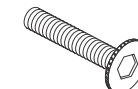
## HARDWARE PACK

XRB14506 (1)





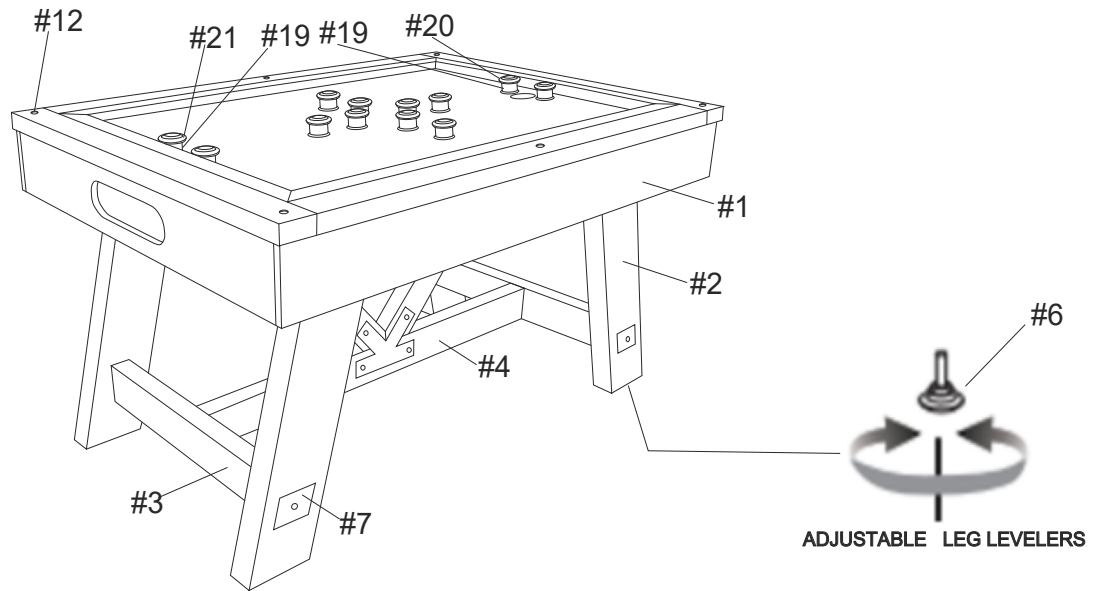

<p><b>13</b></p>  <p>5/16" x 3-1/2" Bolt (16)</p>	<p><b>14</b></p>  <p>5/16" x 2-1/2" Bolt (2)</p>	<p><b>15</b></p>  <p>5/16" x 2-5/8" Bolt (2)</p>	<p><b>16</b></p>  <p>5/16" Washer (16)</p>	<p><b>17</b></p>  <p>Allen Wrench (1)</p>	<p><b>18</b></p>  <p>Allen Wrench with Handle (1)</p>
--	---	---	--	--	--

# BADDAH 54" BUMPER POOL TABLE - OAK

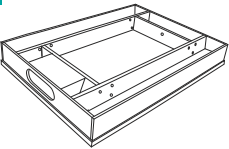
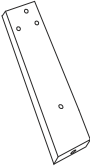
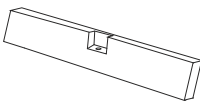
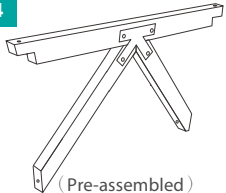
## PARTS LIST

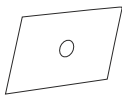

## TABLE PARTS

<p><b>1</b></p>  <p>(Pre-assembled) Table Cabinet XRB14500 (1)</p>	<p><b>2</b></p>  <p>Leg XRB14501 (4)</p>	<p><b>3</b></p>  <p>Cross Beam XRB14502 (2)</p>	<p><b>4</b></p>  <p>(Pre-assembled) Center Beam Assembly XRB14503 (1)</p>	<p><b>6</b></p>  <p>(Pre-assembled) Leg Leveler XRB14504 (4)</p>
<p><b>7</b></p>  <p>Leg Bracket XRB14505 (4)</p>	<p><b>12</b></p>  <p>(Pre-installed) Black Table Top Bump-on XRB14511 (6)</p>	<p><b>19</b></p>  <p>(Pre-installed) Steel Bumper Post XRB14508 (12)</p>	<p><b>20</b></p>  <p>(Pre-installed) Red Bumper Post Ring XRB14509 (6)</p>	<p><b>21</b></p>  <p>(Pre-installed) White Bumper Post Ring XRB14510 (6)</p>

# BADDAH BING 54" BUMPER POOL TABLE ASSEMBLY INSTRUCTIONS - OAK

## STEP 1

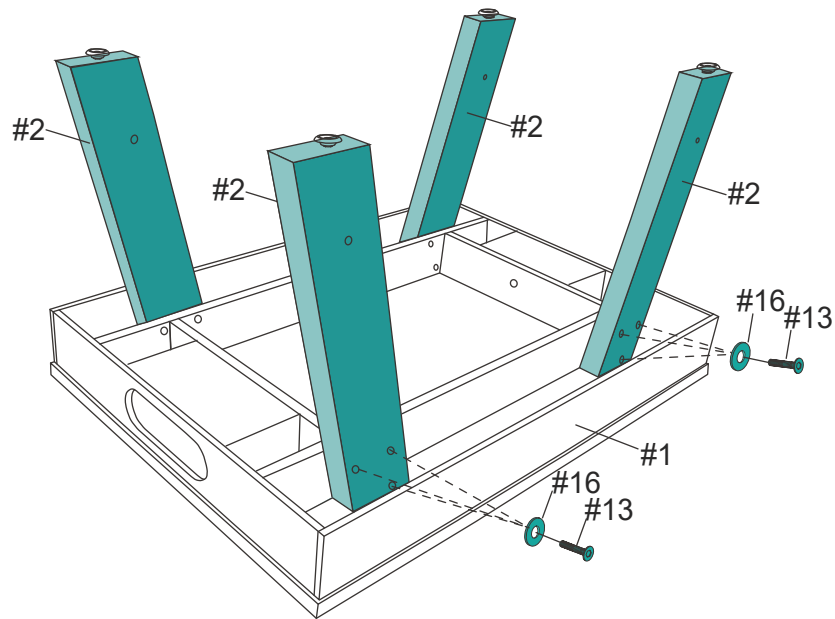

Loosely tighten the #16 Bolt to allow for final adjustments .

## STEP 2

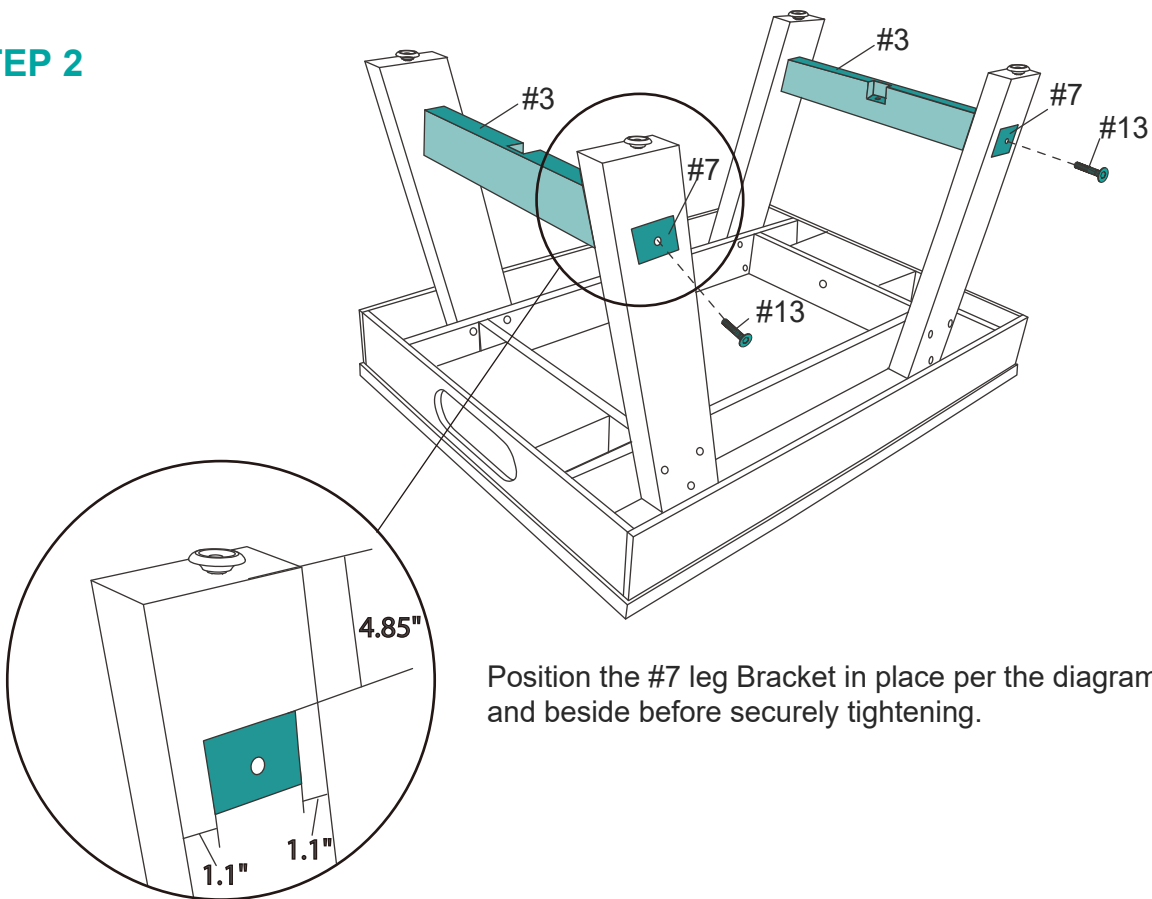

Position the #7 leg Bracket in place per the diagram above and beside before securely tightening.

# BADDAH BING 54" BUMPER POOL TABLE ASSEMBLY INSTRUCTIONS - OAK

## STEP 3

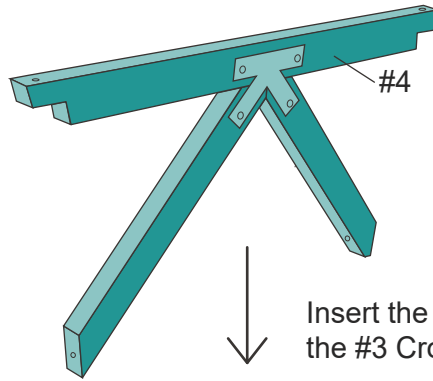

Insert the #4 Center Beam Assembly Into the #3 Cross Beams .

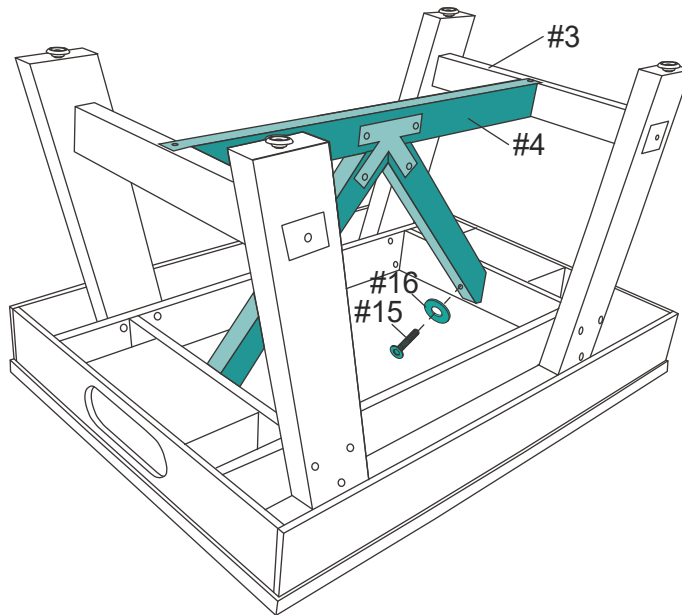

Loosely tighten the #15 Bolt to allow for final adjustments .

## STEP 4

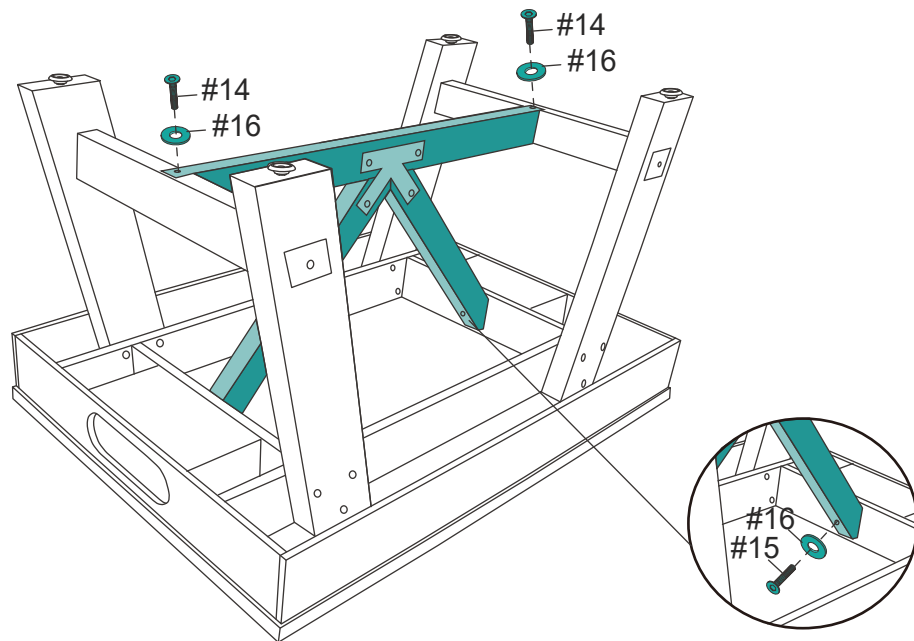

Make final adjustments and fully tighten #14 、 #15 and #16 bolts in place.

# BADDAH BING 54" BUMPER POOL TABLE ASSEMBLY INSTRUCTIONS - OAK

## STEP 5

**CAUTION: THE TABLE IS HEAVY; IT IS RECOMMENDED THAT TWO STRONG ADULTS ASSIST IN FLIPPING THE TABLE OVER TO THE UPRIGHT POSITION AS SHOWN BELOW.**

**HOLD TABLE CORNER**

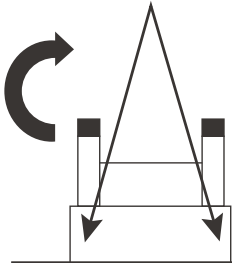

Firmly grasp the table at each cabinet corner area

**CABINET**

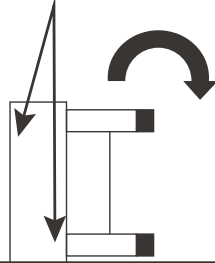

Carefully rotate the table to the upright position by grasping table top

**DO NOT LEAN THE TABLE ON ITS LEGS!**

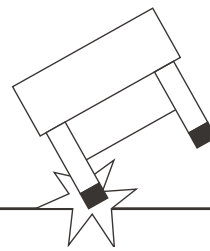

**DO NOT HOLD THE LEGS**

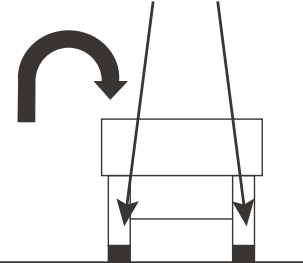

Position the table in its desired location and level the table to the floor by adjusting the leg levelers

## STEP 6

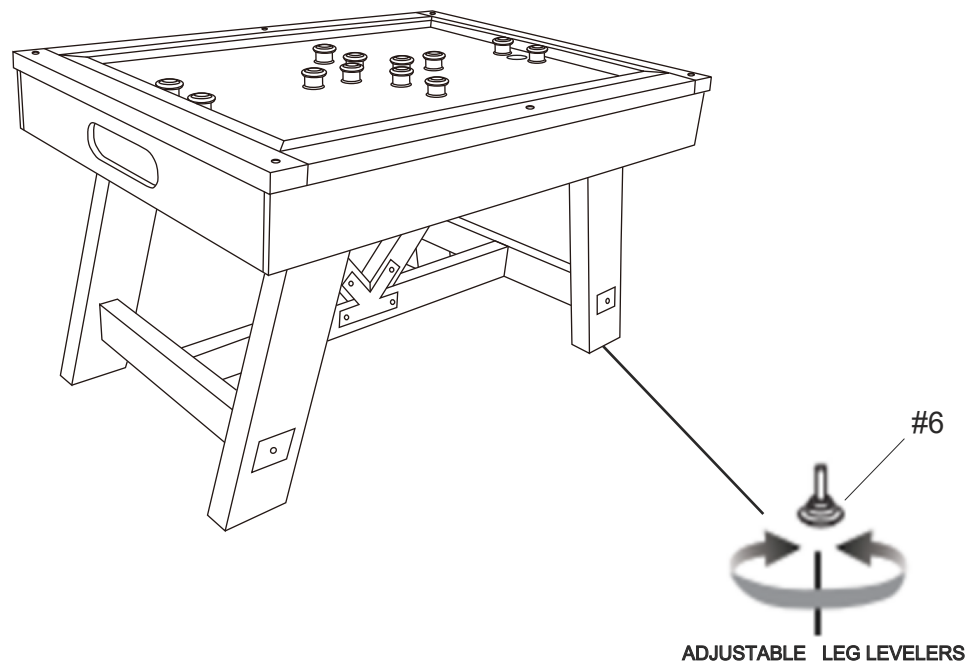

## 1-YEAR LIMITED WARRANTY

This product is warranted to the original purchaser to be free from defects in material or workmanship for a period of 1-Year from the date of the original retail purchase.

This warranty does not cover defects or damage due to improper installation, alteration, accident, or any other event beyond the control of the manufacturer. Defect or damage resulting from misuse, abuse, or negligence will void this warranty. This warranty does not cover scratching or damage that may result from normal usage.

This product is not intended for institutional or commercial use: the manufacturer does not assume any liability for such use. Institutional or commercial use will void this warranty.

This warranty is nontransferable and is expressly limited to the repair or replacement of the defective product. During the warranty period, the manufacturer shall repair or replace defective parts at no cost to the purchaser. Labor charges and related expenses for removal, installation or replacement of the product, or components are not covered under this warranty.

The manufacturer reserves the right to make substitutions to warranty claims if parts are unavailable or obsolete.

The manufacturer shall not be liable for loss of use of the product, or other consequential or incidental costs, expenses or damage incurred by the consumer of any other use.

All warranty claims must be made to Freetime Fun. A purchase receipt with purchase date will be required to process all warranty claims. The model number and part numbers found within the assembly instructions will be required when submitting any parts requests or warranty claims.

**BE SURE TO CHECK OUR WEBSITE AT [FREETIMEFUN.COM](http://FREETIMEFUN.COM)  
FOR GREAT NEW GAMES, SAUNAS, PATIO, AND POOL SUPPLIES FOR YOUR HOME AND FAMILY!  
[WWW.FREETIMEFUN.COM](http://WWW.FREETIMEFUN.COM)**



**BEST IN GAMES, SAUNAS,  
POOL AND PATIO**

**1830 E. FABYAN PKWY, BATAVIA, IL 60510  
PHONE: 1-888-620-6088  
EMAIL: [CUSTOMERSERVICE@FREETIMEFUN.COM](mailto:CUSTOMERSERVICE@FREETIMEFUN.COM)**

**TO ORDER REPLACEMENT PARTS  
VISIT OUR WEBSITE  
[WWW.FREETIMEFUN.COM](http://WWW.FREETIMEFUN.COM)**