



USER GUIDE

OVAL POOLS

Series 5

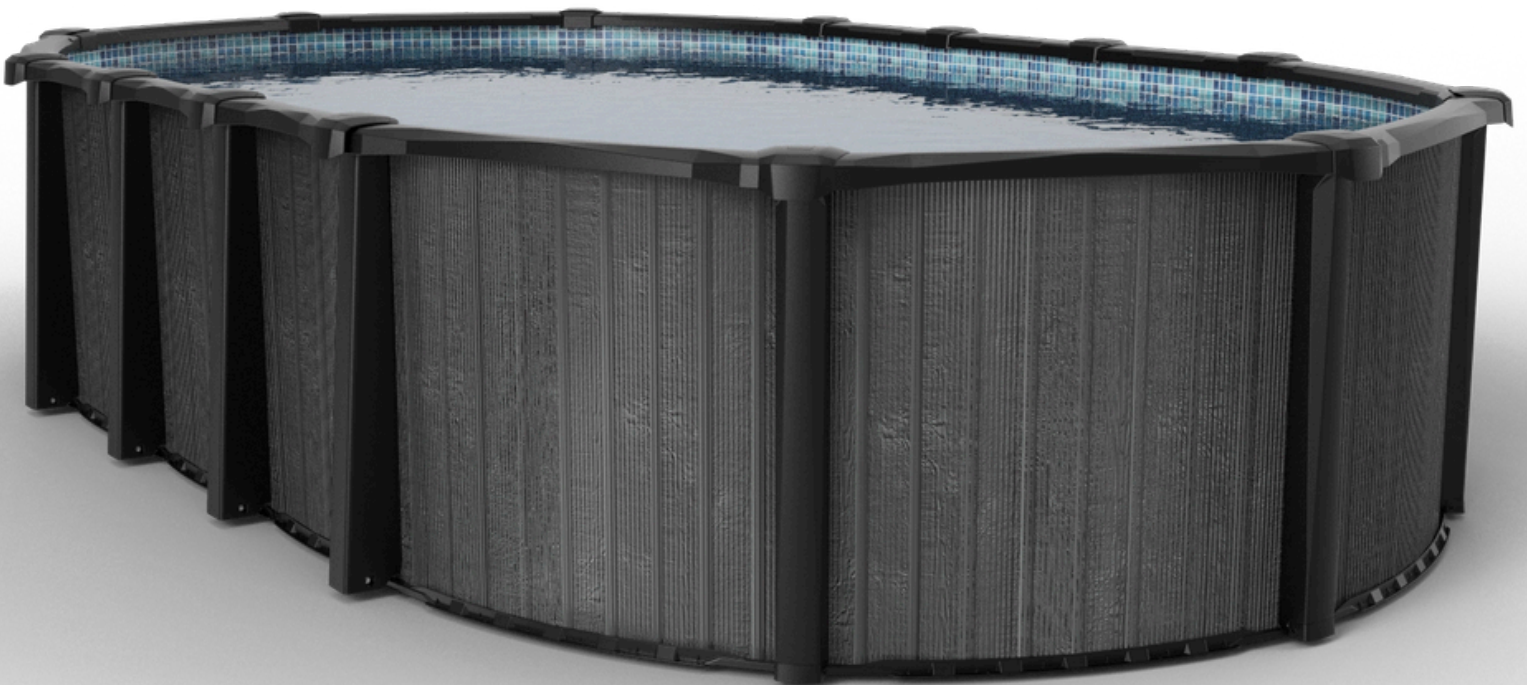

TABLE OF CONTENTS

INTRODUCTION 2

WARNINGS 3

INSTALLATION 4

POOL LOCATION 4

THE FOUNDATION 6

WALL INSTALLATION 12

POOL FLOOR AND COVE 14

INSTALLATION OF THE GEOTEXTILE MAT 14

INSTALLING UPRIGHTS - ROUND SECTIONS 15

LINER INSTALLATION 15

SERIES ASSEMBLY 16

FILLING THE POOL 19

INSTALLING SAFETY STICKERS 20

FOUNDATION DRAINAGE PROTECTION 21

INSPECTION 21

WINTERIZING THE POOL 21

SPRING OPENING 23

REPLACEMENT PARTS 24

INTRODUCTION

Thank you for choosing a Cool Pool™ oval above-ground pool.

We want to ensure you enjoy the best experience with your new pool while using it safely. This manual provides important guidance for installation and operation — please read it carefully before getting started.

If you have any questions or need assistance, please reach out to your authorized Cool Pool™ retailer or contact our technical support team.

All details in this manual are based on the most up-to-date information available at the time of publication. Cool Pool™ reserves the right to make changes at any time without notice and without obligation. No part of this manual may be reproduced without written permission.

READ AND FOLLOW ALL INSTRUCTIONS

Review all instructions supplied with the product before installation, start-up, operation, shutdown, maintenance or winterization.

Failure to comply with warnings and safety messages may result in property damage or personal injury. The user assumes all risks to persons or property resulting from any misuse of this product.

IMPORTANT SAFETY INSTRUCTIONS

Your safety and that of others is very important. This manual provides important safety messages. A safety message alerts you to potential hazards that could injure you or others. Each safety message is identified by a black box and one of three words, DANGER, WARNING or CAUTION.

CERTIFICATION AND COMPLIANCE

THE CONFIGURATIONS LISTED ON THE ICC LISTING COMPLY WITH THE FOLLOWING STANDARDS AND SAFETY CODES:

ICC-ES File PMG-1576

ANSI/PHTA/ICC-4 standards

Standard for above-ground pools / Residential above-ground pools

2024, 2021, 2018, 2015, and 2012 International Building Code. (IBC)

2024, 2021, 2018, 2015, and 2012 International Residential Code. (IRC)

2024, 2021, 2018 and 2015 International Swimming Pool and Spa Code. (ISPSA)

2023, 2020 and 2017 City of Los Angeles Building Code. (LABC)

2023, 2020 and 2017 City of Los Angeles Residential Code. (LARC)

2023, 2020 and 2017 Florida Building Code. (FBC)

2023, 2020 and 2017 Florida Residential Code. (FRC)

2022, 2019, 2016, and 2013 California Building Code. (CMC)

2022, 2019, 2016, and 2013 California Residential Code. (CRC)

2024, 2021, 2018, 2015, and 2012 Uniform Swimming Pool, Spa and Hot Tub Code (USPSHC)*

*Copyrighted publication of the International Association of Plumbing and Mechanical Officials.

WARNING

Your pool is an area of fun, refreshment and relaxation for family and friends. It's designed to be safe and to last for many years. However, careless use of your pool can quickly become dangerous. Pools are subject to wear and tear. If not properly maintained, certain types of excessive or accelerated deterioration can cause the pool structure to fail, releasing large quantities of water that can cause personal injury and property damage. Your pool contains enough water and is deep enough to represent a real danger to its users. That's why it's important to follow and enforce the safety instructions strictly, to ensure safe use of this product. Failure to follow the recommendations listed below may result in serious injury, paralysis or even death.

SAFETY RECOMMENDATIONS

- Make sure all pool users know and follow the recommendations.
- Do not dive or jump. Your above-ground pool is not deep enough to allow safe diving or jumping. This can result in concussion, paralysis, drowning or death.
- Don't run or fight near the pool. When surfaces become wet and slippery, falls can occur, causing serious injury.
- Never leave children unsupervised. It only takes a few seconds for a child to drown.
- Restrict access to the swimming pool ensuring that the ladder is removed, or raised. A barrier is necessary to protect against drowning and near-drowning. Gates are no substitute for constant supervision of children. If you have a deck overlooking your pool, you must have a door fitted with an automatic locking system to restrict access to the water. Don't leave garden furniture around the pool that could allow access to the water. Objects such as toys, chairs, tables or similar items that a small child could climb on must be at least 4' (1219 mm) from the pool. Your filtration system (pump and filter) should be at least 4' (1219 mm) from the edge of your pool. Consult your municipal regulations.
- Life-saving equipment should always be present and accessible near the pool: either a 16' (4.88m) pole with a prehensile tip and/or a .'' diameter, 50' rope attached to a 15'' OD buoy. Poor swimmers should always use a personal life jacket.
- Wait 1 hour after eating before swimming. Cramps can occur, leading to the risk of drowning.
- Do not walk or sit on ledges as they were not designed for this purpose. They can be slippery, leading to dangerous falls.
- Do not consume alcohol or drugs which can distort your judgment and impair your reflexes.
- Do not use your pool if the bottom is not visible. It must be visible at all times from the outside perimeter of the pool. At night, it should always be adequately illuminated.
- Do not use glass bottles or containers near the pool. These can cause serious personal injuries or damage to the pool.
- Do not use your pool during thunderstorms.
- Keep your pool clean and hygienic, as it could cause illness.
- Do not swim alone. If something happens to you, no one will be able to help.
- A list of emergency phone numbers, such as police, fire, ambulance and/or the nearest available rescue units. These numbers should be kept near the telephone closest to the pool.

ELECTRICAL CONNECTION AND GROUNDING OF THE POOL

Once your pool is installed, electrical bonding and grounding are important safety features. Your pool water, all metal components and your body are all conductors and can carry electricity in certain situations. A bonded pool keeps all currents flowing outwards in a bonding wire or grid, where they are safely dispersed.

OTHER RECOMMENDATIONS

Keep an eye on your pool liner. If your liner is a few years old, worn, punctured, discolored or you think it may have been over-chlorinated, it could be defective and cause structural damage to your pool. Please contact a specialist if you have any doubts about the durability of your liner.

Keep an eye on your pool and its equipment. Water leaks around the pool can quickly cause structural damage to the pool. Please contact a specialist if you have any doubts about the plumbing, bottom drain, skimmer, water return, etc. Regularly check your water inlet and skimmer seals to make sure there are no water leaks.

Keep an eye on the ground around your pool. Make sure that the ground around your pool is always stable and well compacted, and that no building gutters run down to it. Weakened ground around the pool can quickly lead to structural damage. Please contact a specialist if you have any doubts about the ground on which your pool rests.

Beware of decks near the pool. Be sure to contact a specialist when your deck is located near the pool, as improper installation, drainage, positioning, construction or shape could result in structural damage to the pool. If in doubt, contact an installation specialist or your dealer. Damage to the pool caused by a deck will automatically void the manufacturer's warranty.

UNPACKING THE POOL PARTS

Before starting, open all the boxes supplied with your pool. Lay them out on the ground and make sure you have all the parts listed in the material lists at the end of this manual. Never begin installation if any parts are missing, damaged or broken. If this is the case, contact your Cool Pool, who will supply you with the missing parts or replace the defective ones. Once the installation is complete, it is assumed that the parts have been inspected and were in good condition at the time of delivery.

N.B. Under no circumstances should the pool wall be detached and unrolled before the bottom rails have been assembled, as this will be very difficult to handle and install.

INSTALLATION

Before starting installation, make sure you have all the tools and materials listed below. Check the contents of the boxes containing the pool parts and make sure that everything is included before beginning installation. All parts in the boxes are important and must be properly installed in the right places. If they are omitted or interchanged, they could cause the pool to fail. Once started, pool installation should be completed as soon as possible. If a part is defective, damaged or missing, contact the Cool Pool™ retailer where you purchased your pool.



The product warranty will be void if all installation requirements and instructions contained in this manual are not followed. Some assembly methods differ from one model to another, so please read the particularities carefully.

TOOLS

- Shovel
- Garden hose
- Hammer
- Rubber mallet
- Soil compactor (manual or mechanical)
- Laser or water transit level or 6' minimum linear level
- Pliers
- Vacuum cleaner
- Gardening rake
- Measuring gallon
- Drill
- Drill
- Ratchet wrench, adjustable wrench and torque wrench (Torque 8.5 N-m (75 lbf-in))
- Phillips or Robertson #3 screwdriver bit
- Hexagonal socket 7/16"
- Wheelbarrow
- Punch 3/16" diameter
- Step ladder
- Vinyl-coated hooks, rope and tent pegs
- Workshop broom

REQUIRED MATERIAL

- 2" Duct tape
- 8" to 12" rod or nails (number of uprights + 1)
- Compaction sand or rock dust or both (see table below)
- River rocks or stones (3/4" minimum)
- Solid Concrete Block 8"x16"x4". (Quantities equal to number of pool posts) (optional)
- Synthetic fiber geotextile pool mat cut to the size of your pool.
- (2X) sheets of 3' x 3' plywood 1/2" thick minimum
- Flexible cardboard 16" X 9"
- Pool cover
- Puncture Proof Liner Pad
- Cool Pool™ pool parts



The use of any material other than that specified for the installation of this pool could accelerate the deterioration of the pool.

INFORMATION REQUIRED FOR POOL INSTALLATION

SIZE OF SWIMMING POOL	12' X				15' X			18' X	
	15'	18'	21'	24'	21'	24'	30'	33'	39'
FINISHED WIDTH OF THE POOL	13'2"	13'2"	13'2"	13'2"	16'2"	16'2"	16'2"	19'2"	19'2"
FINISHED LENGTH OF THE POOL	16'	19'	22'	25'	21'6"	24'6"	30'6"	34'2"	40'2"
CONCRETE BLOCKS 8X16X2 (STRAIGHT SECTIONS / ROUND SECTIONS)	4/6	6/6	8/6	10/6	6/8	8/8	12/8	12/10	16/10
REQUIRED AGGREGATE (TONS)*	2.5	3	3	3	3.5	3.5	4	5	5.5

* The aggregate required for the foundation should be the finest possible stone dust and/or compaction sand. The quantity of aggregate required may vary depending on the quality and straightness of the ground on which the pool will be laid.

REQUIRED POOL EQUIPMENT

A basic circulation and filtration system **MUST BE INSTALLED** as follows:

- A skimmer
- A pool pump
- A filter
- A water inlet

IMPORTANT TO CONSIDER BEFORE INSTALLATION

If you decide to install your pool yourself, we recommend a minimum of 3 people.



Follow the installation steps and recommendations carefully without omitting any. Serious injury and/or material damage may occur.

1. The installation steps in this manual assume that the ground is perfectly straight.
2. Your pool must be perfectly level: once installed, your pool's foundation must have a maximum 1/4" difference in level from one end of the pool to the other, regardless of size.

POOL LOCATION



Your installation must comply with the codes of the authorities having jurisdiction in your area. You may need building, plumbing, electrical, zoning or other permits. Check your local bylaws before beginning installation, as they may affect your choice of pool location.

GENERAL TOPOGRAPHY AND SITE DRAINAGE

The first and most important step is to choose the ideal location for your pool. This will determine the longevity of your pool.

- Ground leveling is crucial. If the pool is more than 1/4" sloped, it will put more weight on the low side, and this uneven weight distribution can cause the low side to sink further, lead to buckling of the studs or add additional stress to the wall, or even cause it to break.
- The site must drain well and be solid. It must slope positively (i.e. away from the pool) and not form depressions, as this would result in water accumulation, compromising your foundation and possibly damaging your pool. You should have at least 6 feet of positive slope around the pool.

TYPES OF PROHIBITED INSTALLATIONS

- Do not bury your above-ground pool. This will automatically void the warranty. Your aboveground pool is not designed to be partially or completely buried. The pool wall draws its strength from the pressure of the water pushing evenly outwards against the wall.
- Backfill provides poor support under the pool, so you should always dig the high side to level the ground, rather than adding sand or soil to the low side to build it up. Backfilling will void the warranty.
- The soil must be free of rocks, stones and tree roots.
- Never install your pool directly on concrete, asphalt, tar paper, grass, peat moss, wood, gravel, earth or clay without proper padding.
- Position your pool away from trees, power lines or cables, clotheslines and buildings (house, garage, etc.). Swimmers could use them to dive or get caught bathers could use them to dive in or get caught, causing serious injuries.

- Never install your pool over underground power lines, gas lines or septic tanks.
- Make sure that none of the building's gutters drain onto your pool's foundation.
- If your pool is located near a deck, it's important to drain the area underneath the deck near the pool.
- It is not recommended to finish a pool deck on top of ledges. If it is, it should be spaced vertically at least 4 inches from the pool.
- The pool must be located at least 6 feet (1.83 m) from any electrical outlet. All 125-volt, 15 and 20 amps outlets within 20 ft (6.0 m) of the pool must be protected by a ground-fault circuit interrupter (GFCI). The 20 ft (6 m) distance is measured via the shortest straight line distance the power cord would follow without piercing a floor, wall, ceiling, door, window or other permanent barrier.
- An installation should never be made on unstable ground, with drainage problems or significant ground movement, or within 33 feet of a tree.

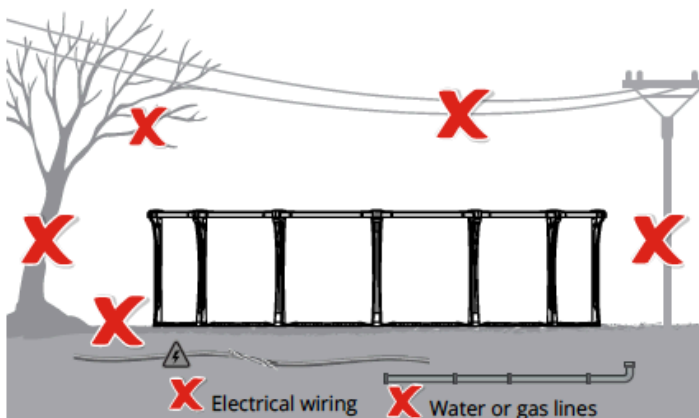
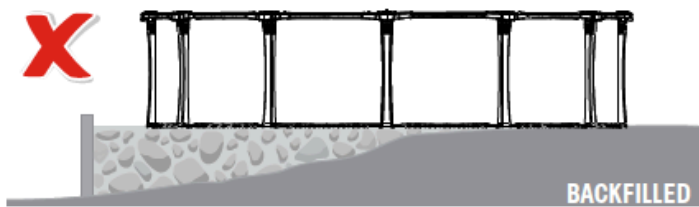
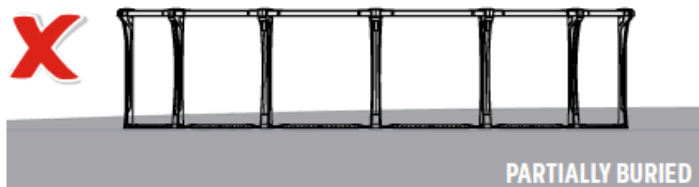
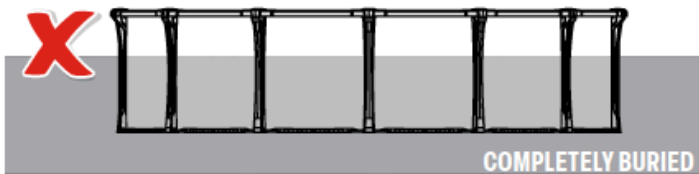
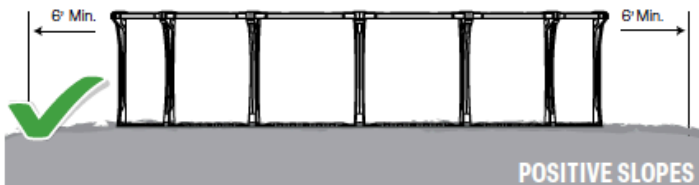

SITE DRAINAGE

Whether it's because it's a new installation, your site is located in a low-lying area of your land, the presence of water veins or simply because your land is poorly drained, you may need to consider installing additional drainage to keep water away from the perimeter of your pool.

CORROSION-RELATED PROBLEMS

It is important to avoid environments that promote corrosion, such as prolonged or permanent exposure to stagnant water. Metal components, such as the wall, must be allowed to dry. Corrosion caused by failure to comply with the recommendations listed below will not be considered a manufacturing defect:

- Do not bury your above-ground pool. Your above-ground pool is not designed to be partially or completely buried. The pool wall must never be in direct contact with the ground or water. The top of the bottom rails must always be visible outside the pool.
- Never install your pool where chemicals have been applied, as this can damage your liner and corrode the pool wall.
- Never install your pool directly on the ground; it should always be installed on a base that drains, such as compaction sand or fine rock dust.
- Never use organic materials that retain moisture under or around your pool, such as: peat moss as a base under your liner, mulch or soil around the outside of your pool for landscaping, etc.
- Choose a location that is not in a depression where water collects, near a slope where there is freeze-thaw or rain runoff, where the soil has drainage problems, in a flood zone or where there are underground water veins.
- Check frequently for leaks in the liner, water inlet and skimmer, and make sure that your filtration system is watertight. Avoiding of checking these points is considered negligence.
- Check the pool wall regularly for impacts or scratches caused by objects such as rocks, lawnmowers, edgers or other objects. These damage the wall's protective finish and initiate corrosion which, over time, will deteriorate the pool wall.
- We highly recommend the use of the Puncture Proof Liner Pad and cove to protect your pools liner.

GROUND WORK PREPARATION



Please note that the installation diagrams presented in this manual are based on a 12x21 oval pool. If you have a pool of a different size, you will find that your pool has more or less metal sections to install.

You should be aware that the leveling and foundation work will take more time and labor than the rest of the steps, which must be carried out properly in order to increase the longevity of your oval pool.

The permitted tolerance for the flatness of the ground and the level of the central metal structure and its rounded ends must be a maximum of $\pm 1/4$ in (6.35 mm). Failure to respect the general tolerance on the overall level of the pool could cause damage to your pool, your property or cause injury to users.

STEP 1

Refer to the "marking diagram" and the "marking dimensions table". Once you have the measurements and you have the location of the pool, you will mark the ground with colored spray paint that will not fade during ground preparation. All pools require extra space all round to allow the foundation to exceed it. In addition, the foot beams of the pool center section will extend 12" underground beyond the pool wall.

1. Drive a stake at points A, B and C (center), at least 6" into the ground. This will define the centers of the round sections and the center of the pool and enable the center sections to be aligned to the measurement specified in the table.
2. Tie a string to a can of spray paint to be able to draw the 2 halves of the circle. Use the radius in the table below to tie the can to the correct length and spray the 2 halves.
3. Measure from the middle of the stakes to draw a straight line on each side to join the 2 halves of the circles to form an oblong.
4. Draw the outer corridor of the trench as shown on the marking diagram.

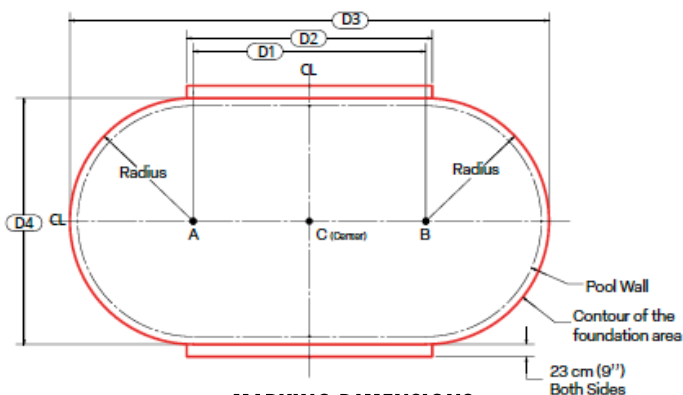

**MARKING DIMENSIONS
METERS (FEET)**

Pool Size	Centre of circles (D1)	Side lines (D2)	Length (D3)	Width (D4)	Radius
12x15'	0.91 (3'0"½)	1.18 (3'11")	5.19 (17'0"½)	4.27 (14'0")	2.13 (7'0")
12x18'	1.83 (6'0"½)	2.10 (6'11")	6.11 (20'0"½)		
12x21'	2.76 (9'0"½)	3 (9'11")	7.03 (23'0"½)		
12x24'	3.68 (12'0"½)	3.93 (12'11")	7.95 (26'0"½)		
15x21'	1.83 (6'0"½)	2.10 (6'11")	6.56 (21'6"½)	5.18 (17'0")	2.59 (8'6")
15x24'	2.76 (9'0"½)	3 (9'11")	7.94 (26'0"½)		
15x30'	4.60 (15'1"½)	4.85 (15'11")	9.78 (32'1"½)		
18x33'	4.60 (15'1"½)	4.85 (15'11")	10.70 (35'1"½)	6.1 (20'0")	3.05 (10'0")
18x39'	6.44 (21'½)	6.70 (22')	12.53 (41'1"½)		

GROUND LEVELING

STEP 1

Once the site has been correctly marked, remove the sod from the installation area. We recommend using a mechanical hoe or shovel. You will need to remove all branches, roots, stones and weeds from the installation area. These could damage your liner and your pool.

STEP 2

The best way to level the ground and remove the grass is to start at the lowest point of the installation surface. Make sure the pool is installed on hard ground. It is not advisable to add soil to level the surface, but rather to scrape off the high spots, as this soil will compact once the pool is full of water, destabilizing the level of the pool and possibly causing damage.

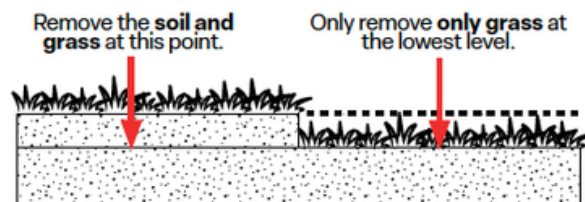

Don't add soil in low-lying areas. It will never be as compact as the existing soil.



Make sure there are no electrical wires, septic tanks, sumps, wells, roots (stumps) or buried debris. There should always be a positive slope away from the pool. Always install the pool on high ground. If it is installed on low ground, this could destabilize it and cause damage.

STEP 3

Once your lawn has been removed and the installation site cleared of all debris, you can start leveling the ground. This is one of the most important steps. The straighter the level (maximum deviation of $\pm 1/4$ " (6.35 mm)), the easier the following steps will be. The best tools for leveling the ground are a gardener's rake, a straight plank and a laser transit level. If you don't have access to a laser transit level, use a carpenter's level on a plank. Check that the entire surface is straight in both axes.

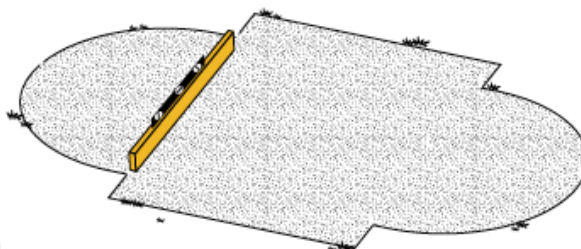

STEP 4

Compact the entire surface of the leveled ground twice using a mechanical compactor. Make sure the floor is perfectly straight after this operation. If this is not the case, start again until the floor is perfectly leveled.

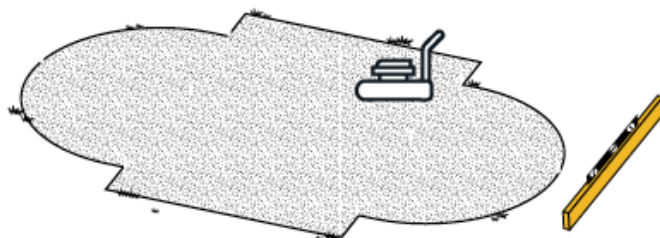

THE FOUNDATION

STEP 1

Place mounds of aggregate around the perimeter of the pool every 4 feet on the dimension line of your pool, which you will spread out in the next step.

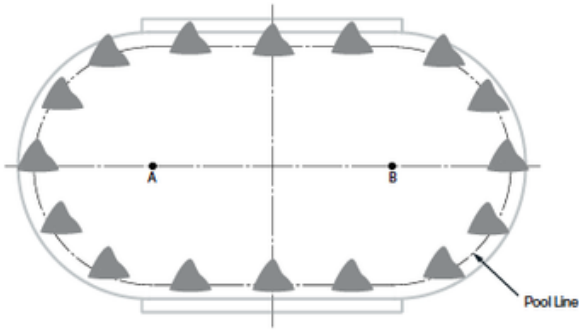

STEP 2

Spread the aggregate around the pool line to a width of 16". That is to say, 8" outside and 8" inside the dimension line of your pool. The thickness of the uncompacted spread aggregate should be between 4 and 5 inches, resulting in a compacted thickness of 2 inches.

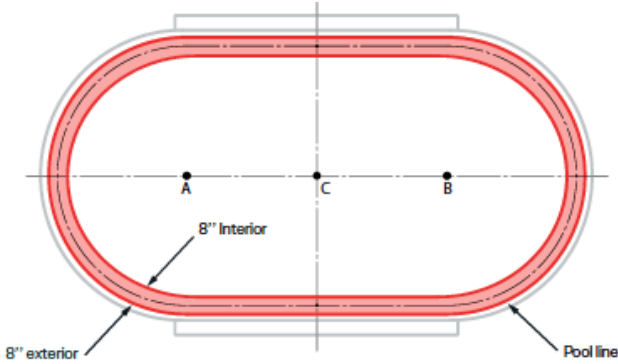

STEP 3

Use the plank you will place on the central stakes and a carpenter's level to level the aggregate in the two semi-circles. Adjust the height of the central stakes to obtain the desired result of 4 to 5 inches of constant, uncompacted aggregate.

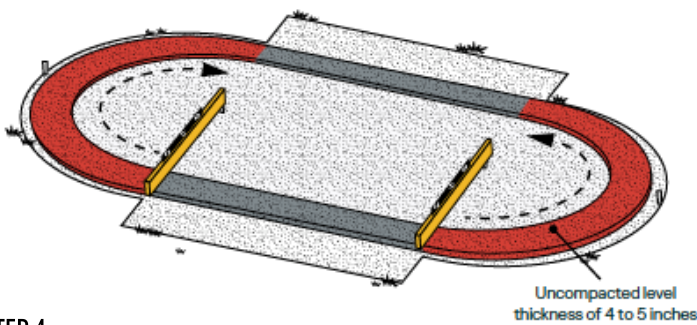

STEP 4

Use the plank and the level to level the straight section, based on the two semi-circles that have already been leveled.

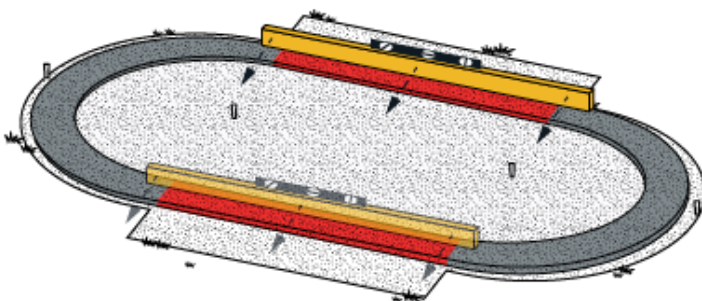

STEP 5

Moisten the aggregate. Compact the outer perimeter twice using a compactor. Measure the flatness and thickness of the aggregate in the circle. Once compacted, it should be 2 inches thick. The base of your pool should rest on a very flat surface with no space under the feet or rails. The maximum slope of the surface is 1/4 inch from one end to the other. If the flatness and thickness are not adequate, start over.

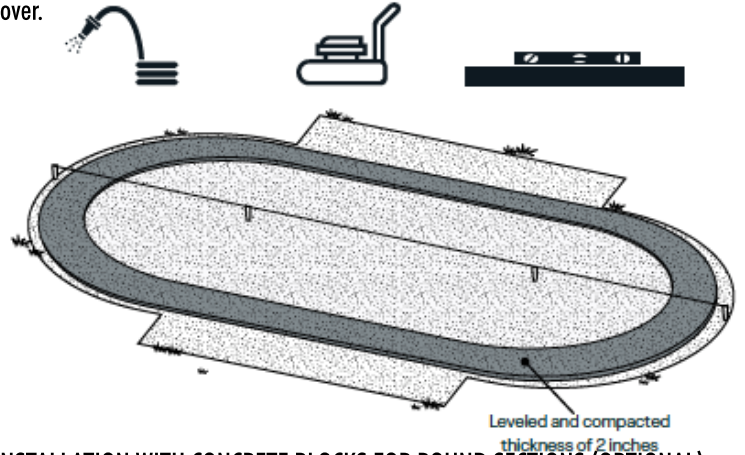

INSTALLATION WITH CONCRETE BLOCKS FOR ROUND SECTIONS (OPTIONAL)

STEP 1

First assemble the rails and bottom plates of the two round sections at position 5 on the gradation system, then place them on their respective radii at the two ends of the pool. Measure from peg A or B to the inside of the rail groove for the exact position, check at all connection feet.

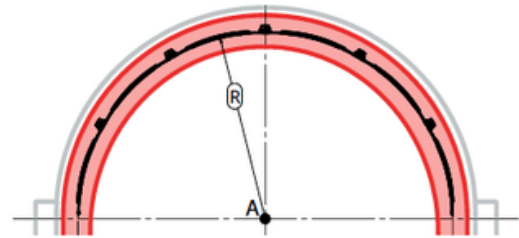

STEP 2

Trace the outline of each bottom plate, then remove them and the rails.

STEP 3

Carefully dig holes the size and thickness of the concrete block. The widest part of the block should be on the radius line and centered with the marked position of the bottom plate.

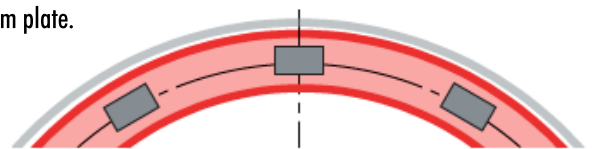

STEP 4

Compact the bottom of the hole using the sledgehammer. Place the block and make sure the top is level with the rest of the foundation. Recompact around the block if necessary.

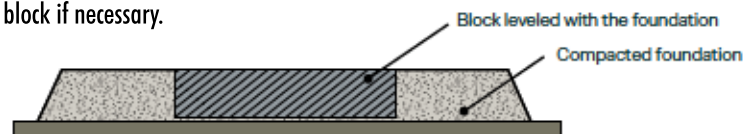

STEP 5

Use the transit level to check that the blocks are all at the same level. If they are not, level any blocks that are not. If you don't have a transit level, check the level using a plank and a carpenter's level.

FOOT BEAM AND BUTTRESS FREE POST ASSEMBLY

For this assembly, you will need the following hardware and parts.

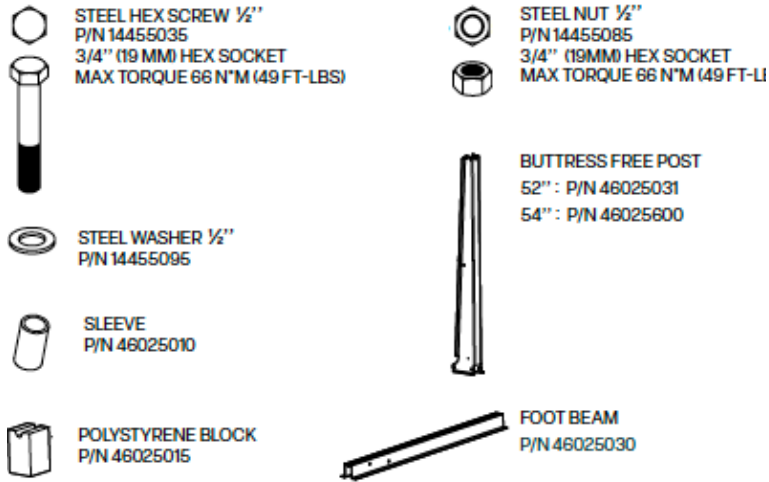

STEP 1

Assemble the buttress free post on the foot beam, aligning the holes.

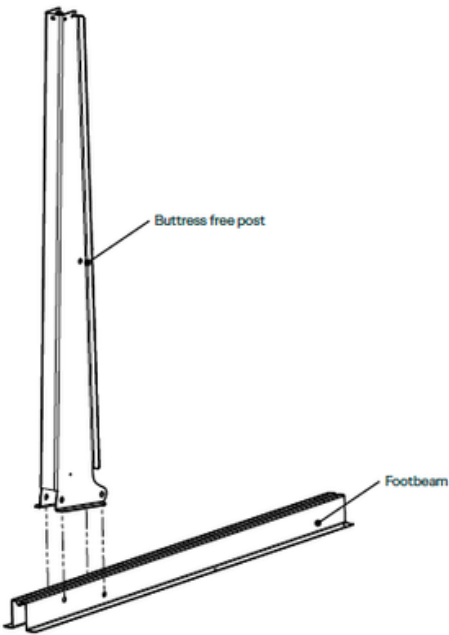

STEP 2

Insert the two sleeves into the foot beam channel, align them with the holes. Insert a washer into a 1/2" screw, then insert through the assembly. Place a washer in the screw on the other side and a nut (14455045). Repeat for the second hole.

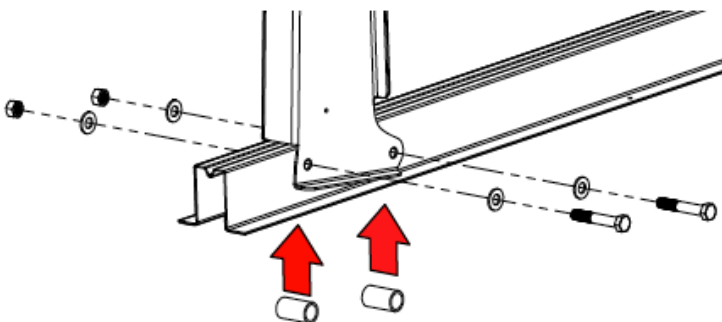

STEP 3

Insert a sleeve and two 1/2" washers on each side into the channel of the buttress free post, aligning the pieces with the holes. Insert a 1/2" washer into a 1/2" bolt, then insert through the assembly. Place a 1/2" washer in the bolt on the other side and a nut.

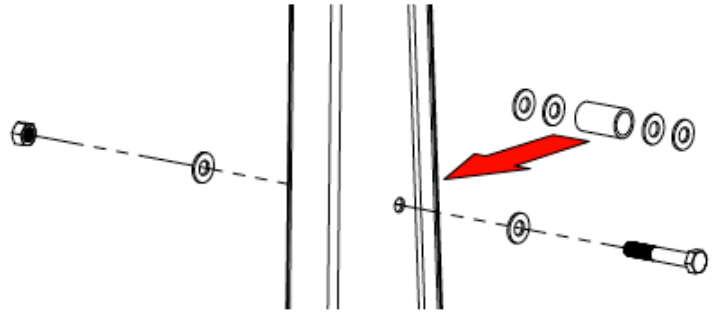

STEP 4

Using a 3/4" hex wrench and a torque spanner fitted with a 3/4" hex socket, set to 66 N•M (49 ft-lbs). Tighten the screws and nuts to the required torque.

STEP 5

Insert the 2 polystyrene blocks (46025015) at each end of the foot beam.

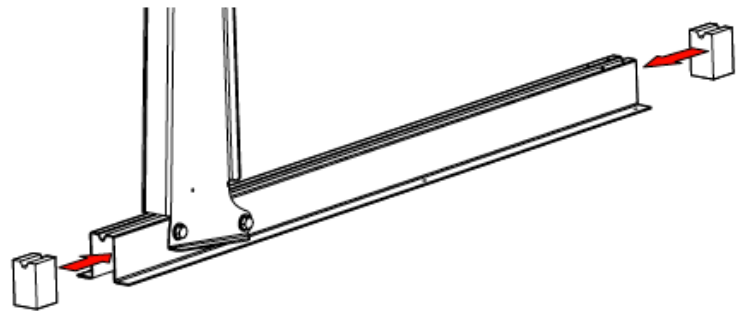

STEP 6

Repeat steps 1 to 4 for each square required for the pool.



The squares are important structural parts and must contain all the parts contained in the assembly stages. Omission of parts or tightening torques could lead to failure or even collapse of the pool. This could result in serious injury and/or material damage

TRENCH DIGGING

STEP 1

You need to dig two trenches on either side of the central section to insert the metal brackets and pressure plates. The top of the foot beam must be level with the compacted foundation aggregate. Refer to the trenching diagram.

STEP 2

You will need to locate the concrete blocks as shown in the diagram on page 9 corresponding to your pool model and dig the block 2" thick. The result should be that the top of the block is level with the bottom of the trench.

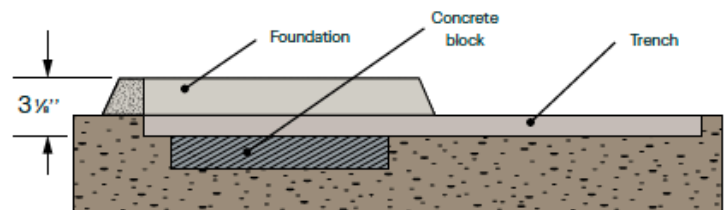

TRENCH DIGGING DIAGRAMS

Refer to the dimensional diagrams for your pool below to mark the location of the trenches on site.

12x15

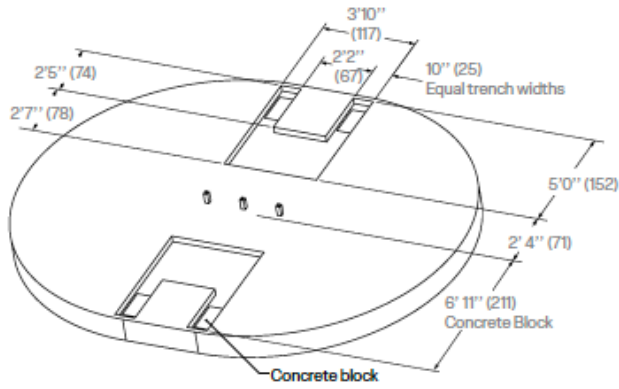

12x18

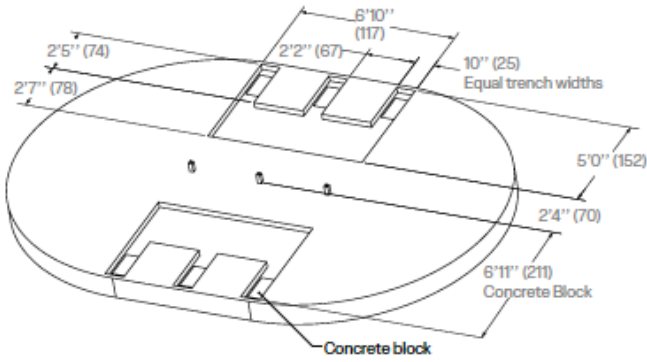

12x21

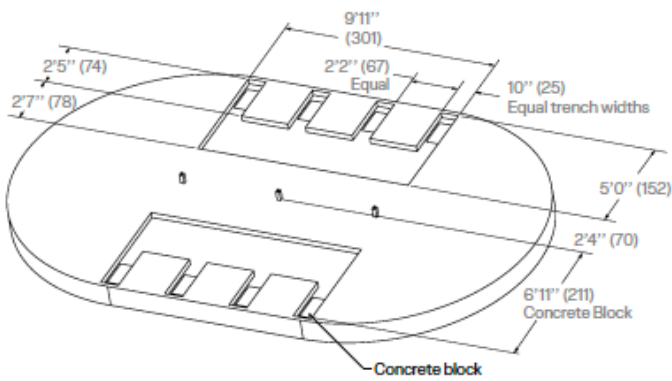

12x24

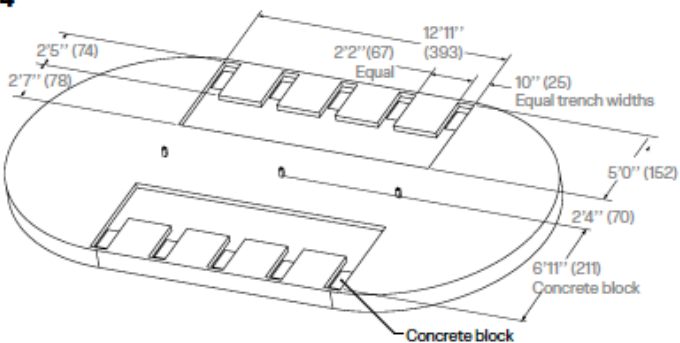

15x21

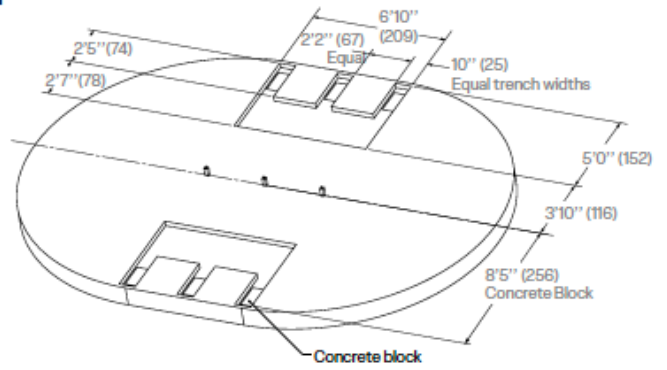

15x24

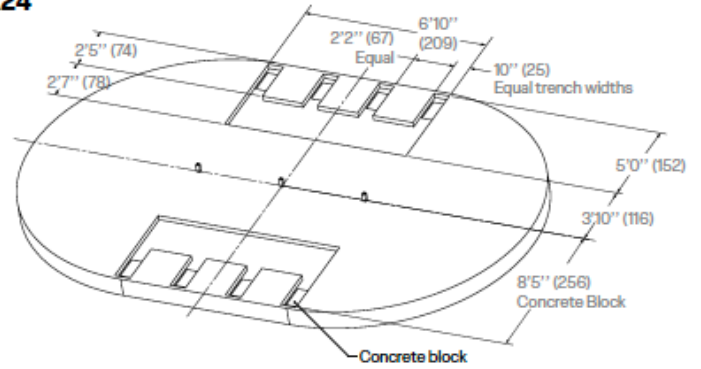

15x30

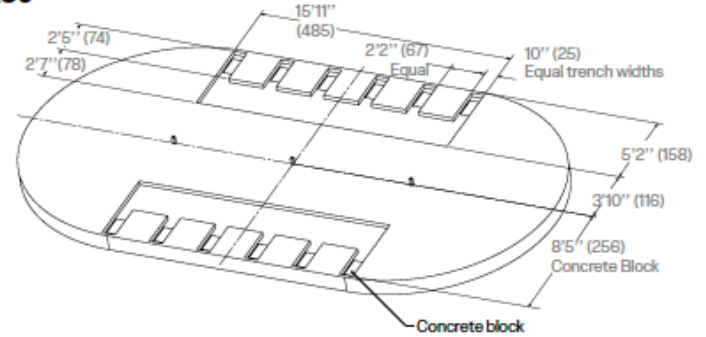

18x33

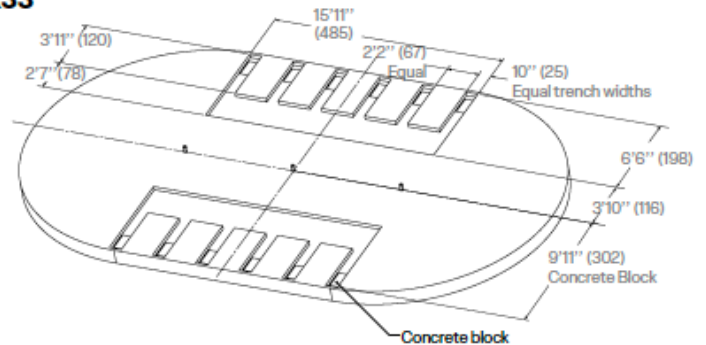

18x39

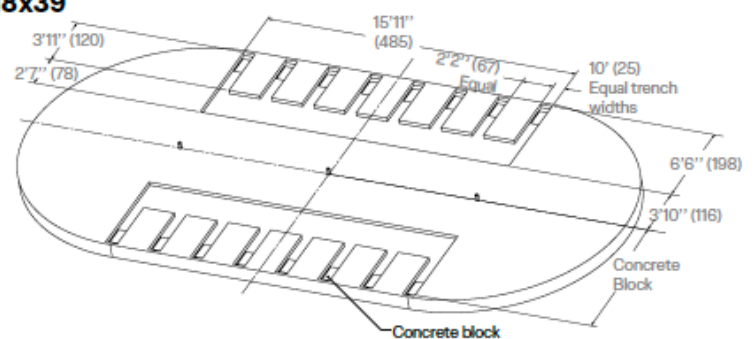

LAYING THE SQUARE ASSEMBLIES IN THE TRENCHES

STEP 1

Place the assembled square assemblies in the trenches. Align each one in the middle of the patio blocks. Align the center of the square on both sides with peg A and B.

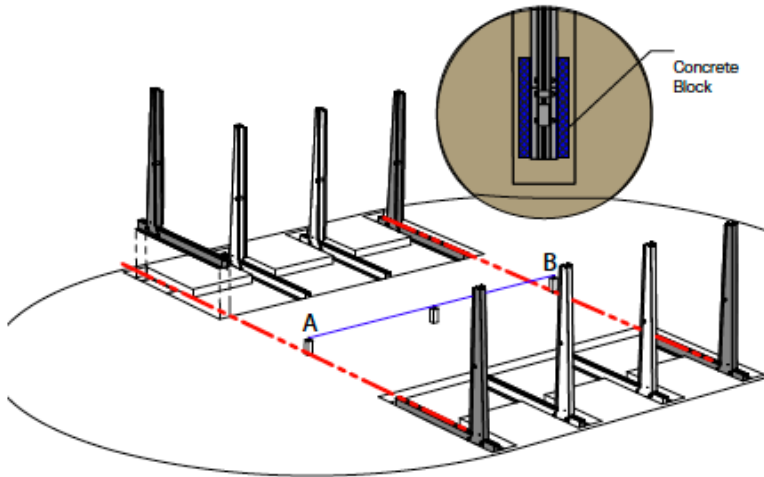

STEP 2

Measure the distance between the buttress free posts and the center of the pool according to the pool squaring table on the page. Use the radius (R) or the measurement (H) divided by 2. If you look at all the buttress free posts in profile view they should all be perfectly aligned.

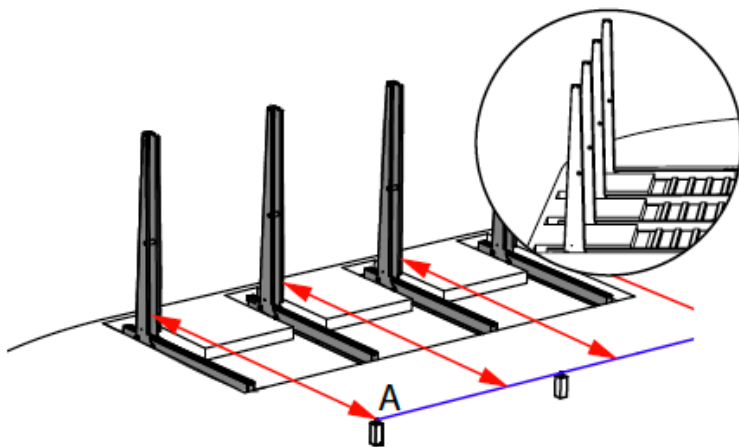

It is important to align the posts as explained in step 2. This adjustment will ensure that the pressure is evenly distributed on the posts in the central section.

PRESSURE PLATE ASSEMBLY

Assemble the pressure plates (46025003) to the foot beams in the holes provided. Each plate is assembled using four no. 12 metal screws (14433700-ZINC). Repeat until all the plates are assembled.

P3 - PHILLIPS DRIVE
P/N 14433700-ZINC
MAX TORQUE 4 N-m (35 in-lbf)
SCREW AT LOW SPEED



It is important to use the zinc-plated metal screws provided for this purpose. These screws are designed for assembly in galvanized steel. If you use other screws, they will either break and/or prematurely initiate corrosion on the metal structure.

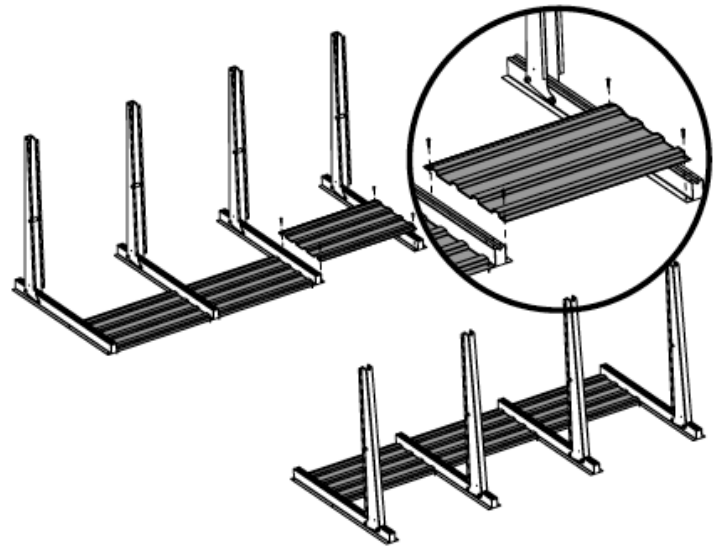

TIE STRAP ASSEMBLY

Refer to the table for the part number required to configure the tension bands and assemble using 1/4"-20 x 0.500" hex head machine screws (14455075) and 1/4"-20 nuts (14455085).

Remove the "radius pegs" before screwing the bands to each end. Make sure you identify your center on the tie strap with a pencil. Screw the assembled tie straps to the foot beams at each end with screws (14433700-ZINC).

P3 - PHILLIPS DRIVE
P/N 14433700-ZINC
MAX TORQUE 4 N-m
(35 in-lbf)
SCREW AT LOW SPEED



7/16" (11mm)
HEX SOCKET 7/16"
P/N 14455075
MAX TORQUE 7.5 N-m (66 in-lbf)



7/16" (11mm)
HEX SOCKET 7/16"
P/N 14455085

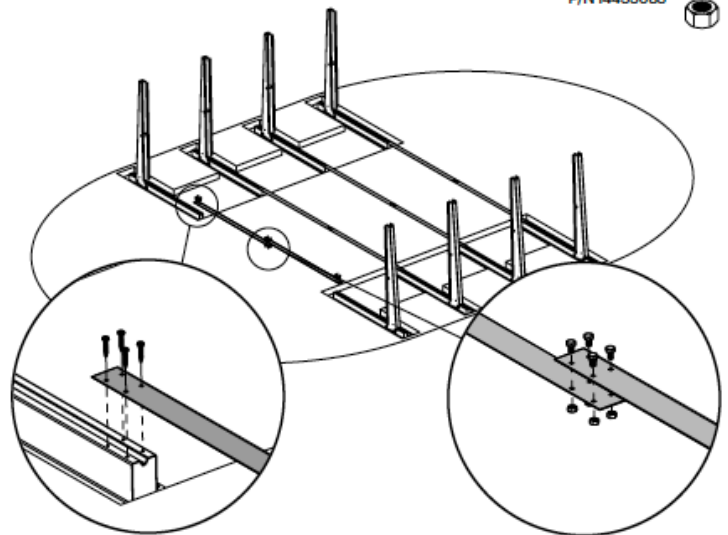

POOL DIMENSIONS	CONFIGURATION OF TIE STRAPS PER SECTION
12' X ()	1 X P/N 46025007 (35") + 1 X P/N 46025006 (40")
15' X ()	2 X P/N 46025005 (55")
18' X ()	2 X P/N 46025005 (55") + 1 X P/N 46025006 (40")

SQUARING THE STRAIGHT SECTION

This step is very important, as it will ensure that the structures in the central section are parallel and well aligned. Refer to the dimensions in the table. The buttress free posts on each side must be aligned with each other. Each square assembly should be positioned centered as possible in the middle of the concrete block. Measure the distance from the bottom of each buttress free posts to the center of the pool. Measurement A & B must be the same to ensure that the two straight sections are parallel and square to each other.

SQUARING THE POOL
Measurements in Meters (Feet)

POOL WIDTH	A = B	C	D	E	F	G	H	I (Mur)	R
12'	12x15 (12' 4" 1/4)	3.77 (12' 4" 1/4)	1.39 (4' 6" 1/4)	2.57 (8' 6" 3/4)	3.35 (10' 12")	N/A	3.64 (18' 0")	4.58 (15' 0")	1.82 (6' 0")
	12x18 (13' 5" 3/4)	5.50 (18' 0" 1/4)							
	12x21 (15' 0")	6.64 (21' 0" 1/4)							
	12x24 (17' 0" 1/4)	7.34 (24' 0")							
15'	15x21 (16' 2")	1.40 (4' 7")	2.67 (8' 9")	3.68 (12' 1")	4.32 (14' 2")	N/A	4.58 (15' 0")	6.41 (21' 0" 1/4)	2.29 (7' 6")
	15x24 (17' 6" 1/4)							7.33 (24' 0" 1/4)	
	15x30 (21' 3" 1/4)							9.18 (30' 0" 1/4)	
18'	18x33 (23' 6")	1.41 (4' 7" 1/4)	2.73 (8' 11" 3/4)	3.88 (12' 8")	4.73 (15' 6" 3/4)	5.27 (17' 3" 1/4)	5.48 (18' 0")	10.09 (33' 1" 1/4)	2.74 (9' 0")
	18x33 (27' 9")							11.93 (39' 1")	

18' POOL

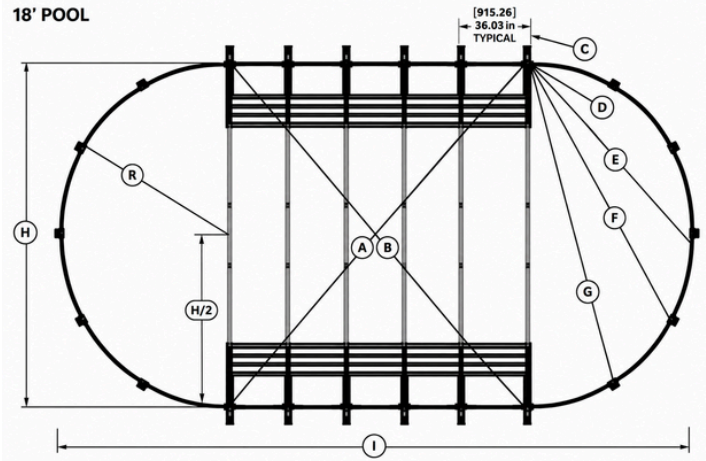

FILL UP THE TRENCHES

Before filling the trenches, make sure that the tops of the foot beams are level with the foundation and the round sections. If this is not the case, adjust the level of the foot beam so that they are level. Fill the trenches with rock dust as well as the center of the pool so that the general level of the ground is equal to the foundation. Add water to the rock dust and compact the soil twice. Make sure the ground is level after compaction.

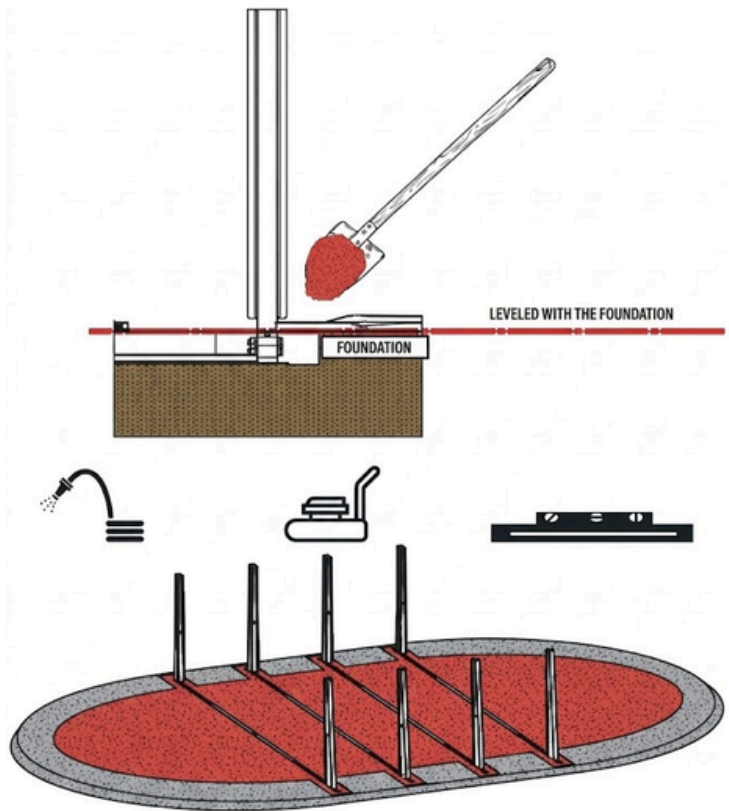

BOTTOM PLATES AND RAILS ASSEMBLY

STEP 1

Insert the rails into the bottom plates of the straight section.

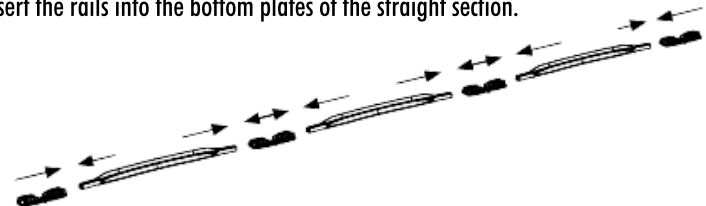

12' POOL

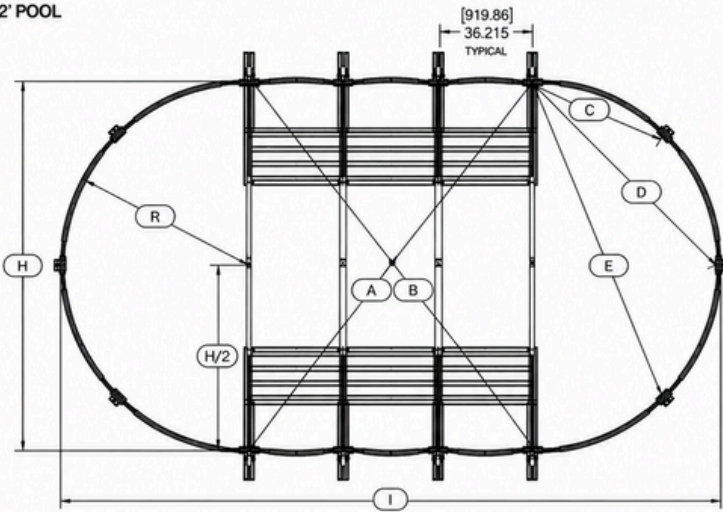

15' POOL

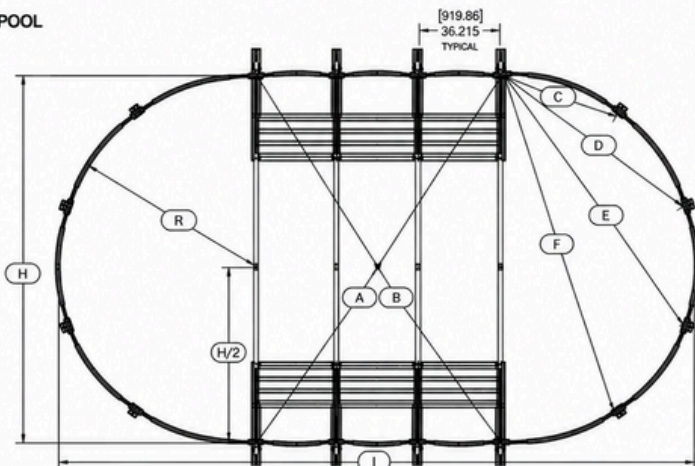

STEP 2

Once assembled, fix all the bottom plates to the holes in the foot beams using metal screws on both sides of the structure.

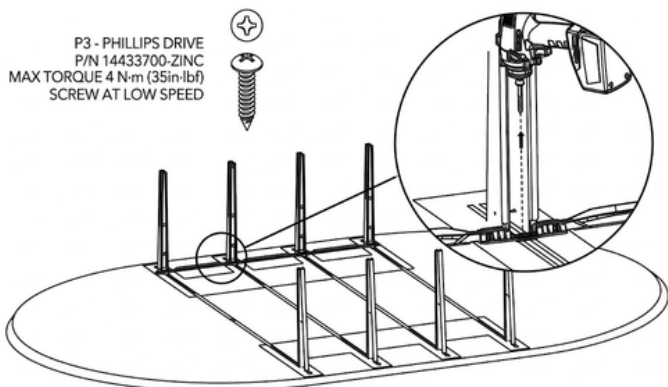

RAIL ASSEMBLY - ROUND SECTION

STEP 1

Add aggregate or sand for the "bottom" to the inside of the pool before installing the rails, connecting bottom plates and unrolling the wall. You'll need enough aggregate or sand to make a 1.5" to 2" thick base once compacted plus the cove. This step is important before unrolling the wall.

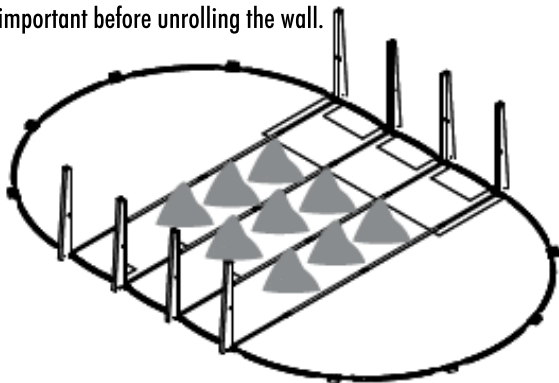

STEP 2

Make sure that the surface from the straight section to the round sections is level.

STEP 3

Assemble the round sections with the bottom plates and long rails.

STEP 4

Connect the rails of the round sections to the bottom plates of the right-hand section.

STEP 5

Measure the distance from the central stake (you made a mark on the tie straps) to the inside center of the rails (dimension "R" when squaring the straight section) and adjust to the radius of your pool (see table on page 11). Drive a stake in front of each bottom plates, in the middle, to maintain the position of the circle when installing the wall.

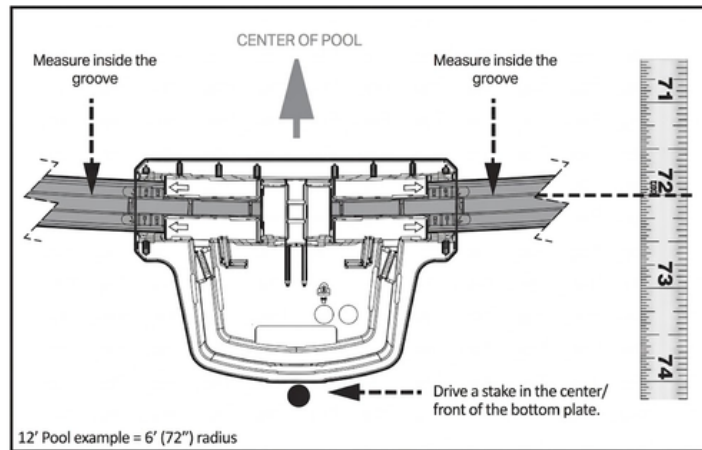
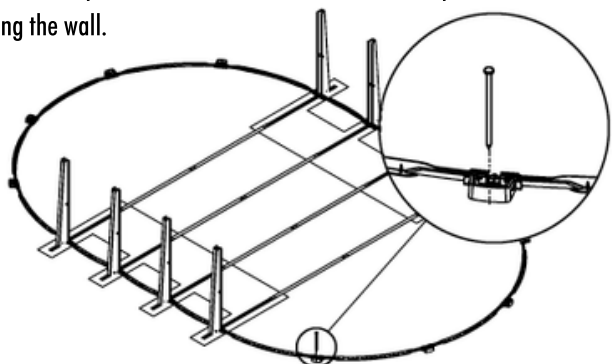

WALL INSTALLATION



Do not install the wall in windy or stormy weather. Wait for a calm day. At least 3 people are needed to install the wall. This could result in serious injury or even death.

STEP 1

Before you start installing the wall, make sure you have the following items within the circle of the pool rails: two sheets of plywood, pool cove and a stepladder to be able to climb out of the enclosure formed by the assembled pool wall.

STEP 2

Note that the hole for the water return and the skimmer are located at the end of the start of the rolled-up wall, so position the roller to start the roll-out of your pool wall where you wish to position these elements. It is recommended that the skimmer and water return are located in the round sections to ensure good water circulation in the pool.

STEP 3

Position the 2 sheets of plywood inside the pool circle near where you want to position your pump and filter. Remove the wall from its box and place it on a sheet of plywood.

STEP 4

Start unrolling the wall by inserting the bottom of the wall into the bottom rail (already positioned). The beginning of the wall should be in the center of a connecting foot to hide the closure behind an upright. Use the plywood sheets so that the wall doesn't touch the ground.

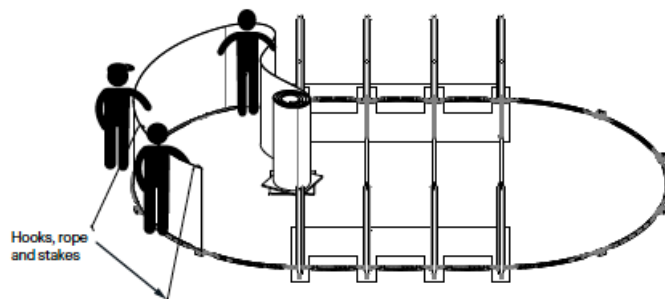

Do not put sand inside the bottom rail, as this would make it difficult to insert the wall into it. It is mandatory to clean the inside of the rails to facilitate the insertion of the wall into them.

STEP 5

We suggest installing the top rails on top of the wall as it is unrolled, to give the wall greater stability and rigidity. It's important to support the top of the wall from the outside until it's fully installed in the bottom rail and closed. Support it by securing the top of the sheet with vinyl coated hooks attached to a rope and staked into the ground with tent pegs.

BASIN ASSEMBLY

Once the wall has been completely unrolled and inserted into the bottom rails, 3 situations may occur:

- Wall looks too long (it is not). See step 1.
- Wall appears too short (it is not). See step 2.
- The assembly holes at both ends of the wall line up perfectly. Proceed to step 3.

STEP 1

If your wall seems too long, the spacing between the rails in the feet needs to be enlarged. Gently tap the inside of the feet outwards, so that the pool's circumference expands slightly. If the wall overlap is long, you'll need to spread the expansion of the pool over several connections feet.

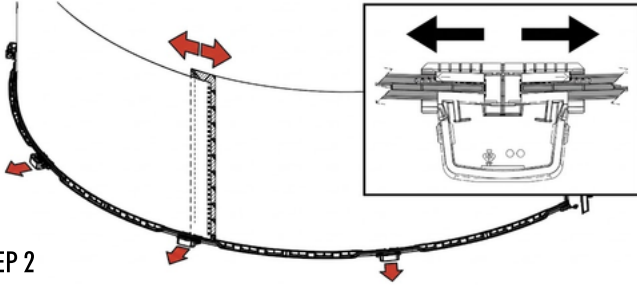

STEP 2

If your wall seems too short, the spacing between the rails in the feet needs to be narrowed. Gently tap the outside of the feet inwards to reduce the pool's circumference slightly. If the wall overlap is short, you'll need to spread the expansion of the pool over several connections feet.

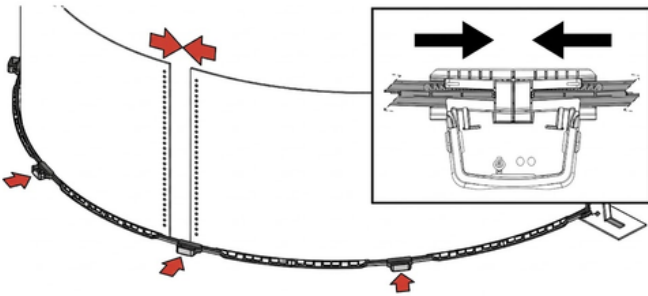

If you have carried out one of the two steps (1 & 2), you must double-check the spacing between the rails in each foot to ensure that the spacing is equal on both sides of the center of the foot.

STEP 3

Once the holes at the 2 ends of the wall are aligned (or very close to it), you can assemble them. To do this, place the two ends of the wall one on top of the other, then add a wall bracket on each side of the wall (inside and outside). To help you align the holes, use a punch to pass through the holes so that they align correctly. Then install the screws (interior) and nuts (exterior), but don't tighten them just yet. It's best to put a screw at the bottom, middle and top to facilitate assembly.

Make sure all holes have screws and nuts. Once all screws and nuts are in place, tighten them to a torque of 8.5 N-m (75 Lbf-in).

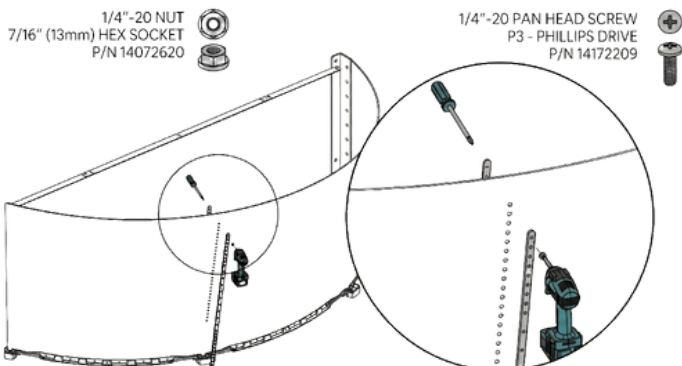

The screw heads must be inside the pool. Set a torque spanner to 8.5 N-m (75 in-lbf)



TORQUE 8.5N·M
(75 IN·LBF)

Tighten the screws one by one as you go up and down, without forgetting any, which could cause long-term problems.

STEP 4

Cover the inside wall joint and screw heads with 2" (50mm) wide Duct Tape. Overlap 3 layers of tape to ensure that the liner is well protected from the sharp corners of the screws, and that the curvature of the liner at this position is softened.

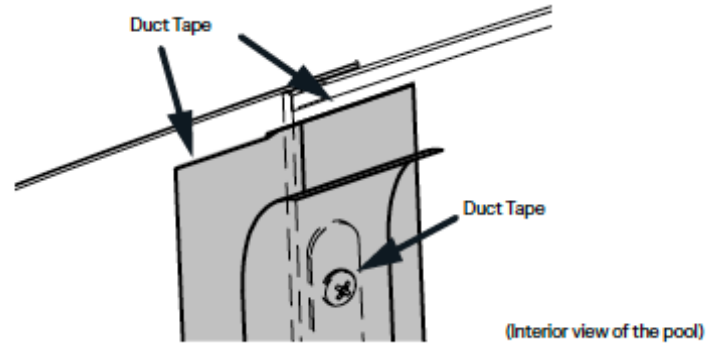

STEP 5

Once the wall is assembled, carry out additional checks to ensure that the round sections of the pool are perfectly round. To do this, check the radius of the pool from the centre to the inside of all the rails to ensure that each distance is the same. If this is not the case, adjust the connection feet by pushing them in or out to obtain perfectly round sections.



The pool must be level throughout its entire perimeter. A pool that isn't level throughout can be dangerous and collapse.

Once the wall has been installed, check the position of all the rails in each foot. Each rail must be positioned so that the gaps are equal at the center of the connecting foot. Example below: the space is equal between the end of the two rails and the center of the foot. You can refer to the gradation on the rail to ensure that the figure is equal on both sides.

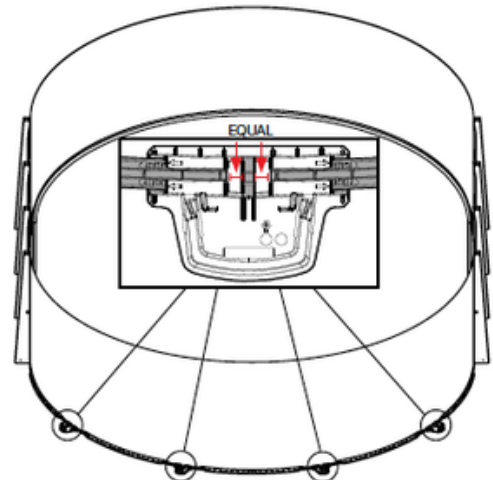



The pool floor is not optional; it must be manufactured according to the specifications in the manual.

POOL FLOOR AND COVE

STEP 1

We recommend that a 12" wide strip of wall foam be glued to the inside of the wall from 8" above the floor, secured with duct tape, and running down to the floor to prevent any contaminants in the aggregate from affecting the metal wall.

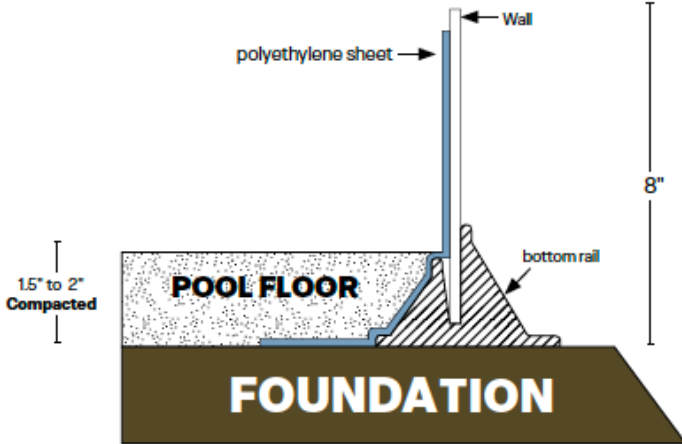

STEP 2

Once the wall foam is in place, starting from the aggregate previously placed inside the pool, begin raking and leveling an even layer spread over the entire inside surface of the pool.

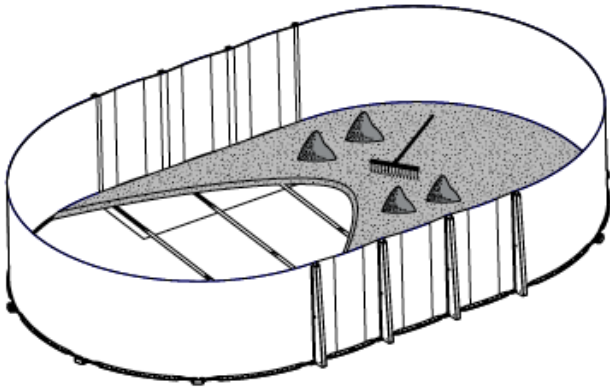

STEP 3

When this is complete, use a hose to soak the soil, then compact with a mechanical compactor. You should have a thickness of 1.5" to 2" of compacted aggregate.

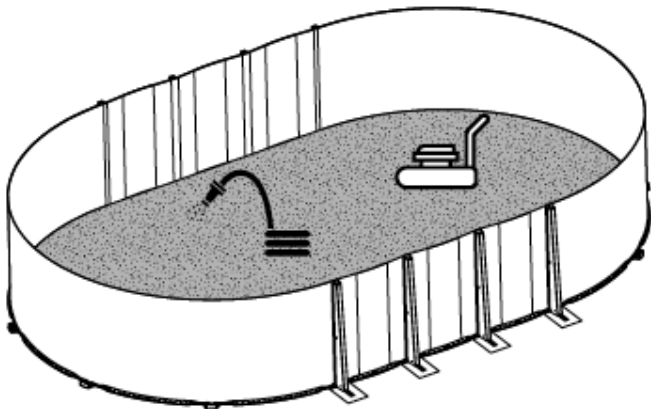

STEP 4

Install pool cove at the base of the pool wall and Puncture Proof Liner Pad. Press the pad into the base after exposing its sticky tape and push it firmly in place. This will form a triangle where the pool wall meets the liner pad and will protect your liner from stress and wear.

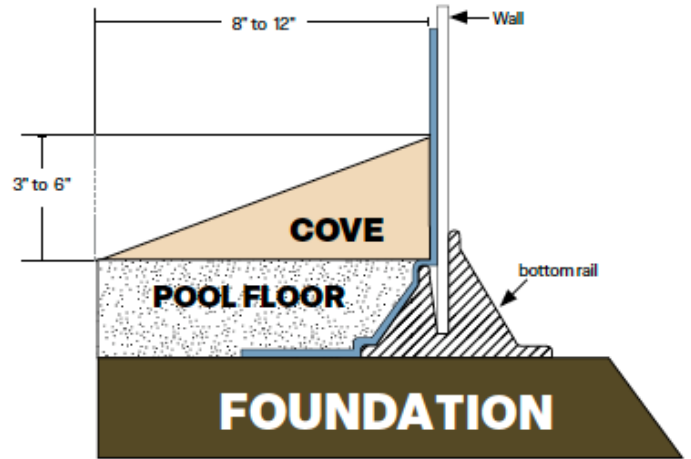

INSTALLATION OF THE GEOTEXTILE PUNCTURE PROOF MAT



Use a quality 100% synthetic needle-punched geotextile mat designed for this purpose. Never install the liner directly on the rock dust or peat moss.

STEP 1

Roll out the pre-cut geotextile Puncture Proof mat to the size of the pool.

STEP 2

Water the geotextile Puncture Proof mat to spread it out and hold it in place.

STEP 3

Once wet, using the broom, place the fabric from the center outwards, sweeping to remove wrinkles.

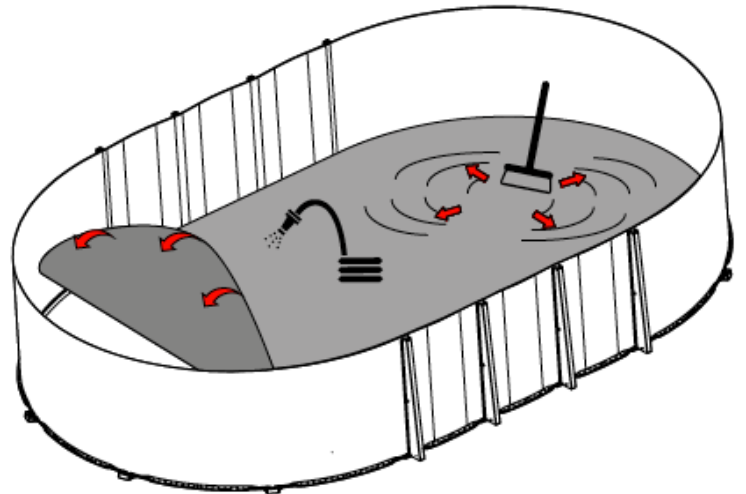

INSTALLING THE UPRIGHTS - round section

Before installing the uprights, check that the rails are correctly centered in the connection feet. Adjust if necessary.

STEP 1

Insert the uprights into the feet. Push the upright down until you hear a click.

STEP 2

There are spaces on each side of the connecting feet for installing screws. Installation of these screws is mandatory to make the assembly even stronger against freeze-thaw ground movement. These screws are mandatory in order to preserve the warranty.

Do not install these screws immediately. Wait until the ledges have been installed before installing these screws.

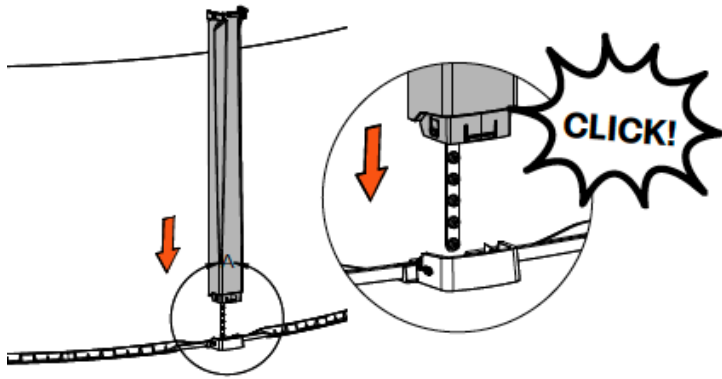

LINER INSTALLATION (GENERAL)

REFER TO THE LINER MANUFACTURER'S INSTRUCTIONS BEFORE PERFORMING THIS STEP.

The liner is generally smaller than the structure. We recommend laying the liner in the sun one or two hours before installation to allow it to warm up. It will stretch better under these conditions.

Do not install the liner on a cold, sunless day (65°F minimum). Avoid using very cold water to fill up the pool.

The Cool Pool™ pool must be installed with a "U/J-Hook" or "Overlap" type liner.

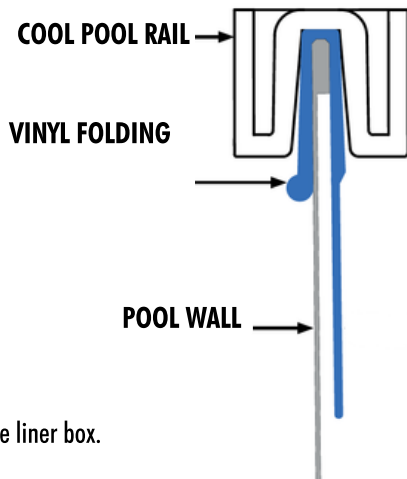

STEP 1

Open the liner box.



Do not use sharp objects to open the box. This may damage the liner.

STEP 2

Take the canvas out into the sun unroll it to let it warm up.

STEP 3

Inspect the liner, joints and surface for holes.



To avoid damaging the liner, remove your shoes when walking on it.

STEP 4

Lay the liner in the pool with the patterns facing upwards. The liner seam that runs around the bottom of the pool should be centered with the pool. The other seams should form parallel straight lines.

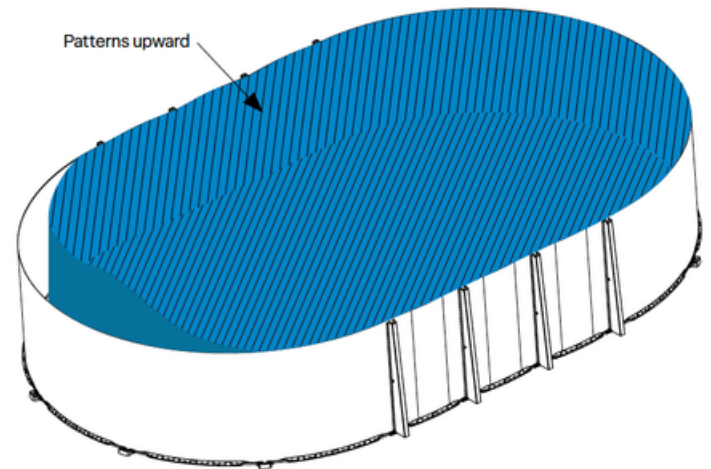

STEP 5

Stretch the liner to remove as many creases as possible from the bottom of the pool.

ASSEMBLING THE LINER TO THE POOL WALL

FOR INSTALLATION WITH HOOKED POOL LINER (U/J HOOK)

STEP 1

The top side of the canvas has a vinyl fold where there is no pattern. Open this fold with your fingers and hang it on the top of the wall.

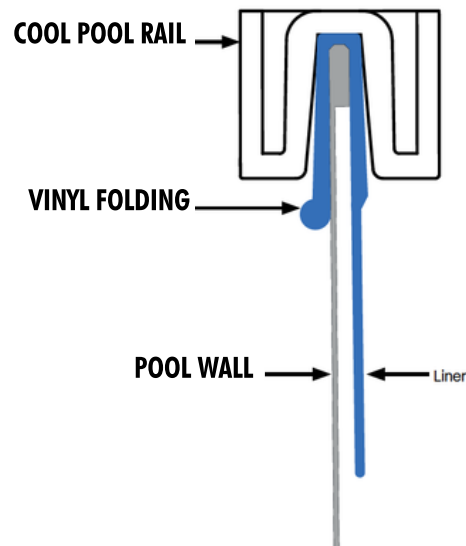

STEP 2

Do this all the way around the pool. The liner should not have any wrinkles, even in the portion running up the walls. If it does, adjust the liner either by turning the bottom, or by adjusting the installation of the fold around the wall.

INSTALLING THE TOP RAILS

As you install the liner fold, assemble the top rails to secure the assembly. Position the top rails so that they line up with the bottom rails, since the uprights will have to reach the junction of the rails (top and bottom).

Insert the liner into the slot and press along the rail from right to left.

Use a rubber mallet to tap the top rails gently into place, trapping the canvas in the rail.

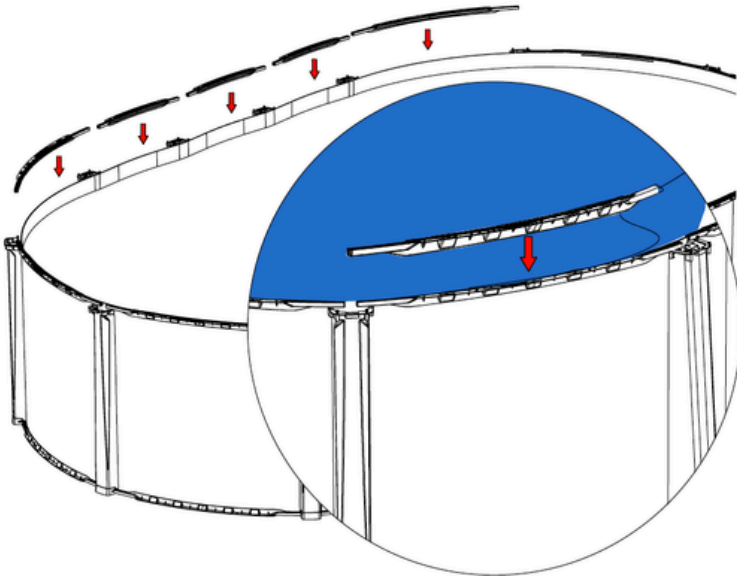

INSTALLING THE TOP PLATES - ROUND SECTIONS

STEP 1

From the outside, tilt the top plate so that the inner part hooks onto the top rail. Lower the plate, then slide it onto the upright, and press down.

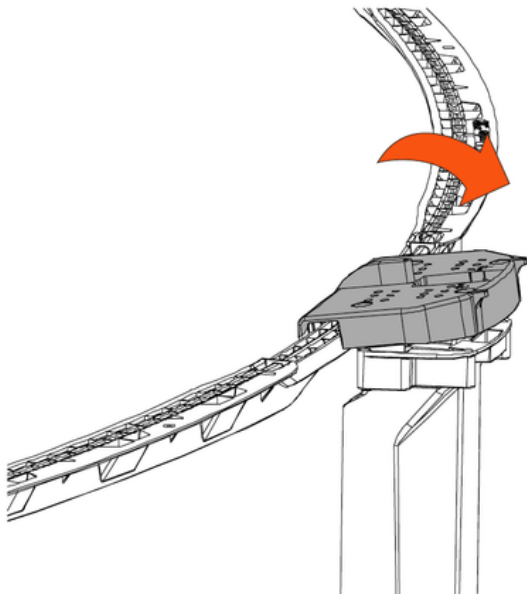

STEP 2

Make sure the holes in the top plate line up with those in the uprights. Install the 4 self-drilling screws (14455032) to assemble the top plate to the upright.

P3-PHILLIPS DRIVE
P/N. 14455032
SCREW AT LOW SPEED
Max torque 4 N-m (35 lb-fin)

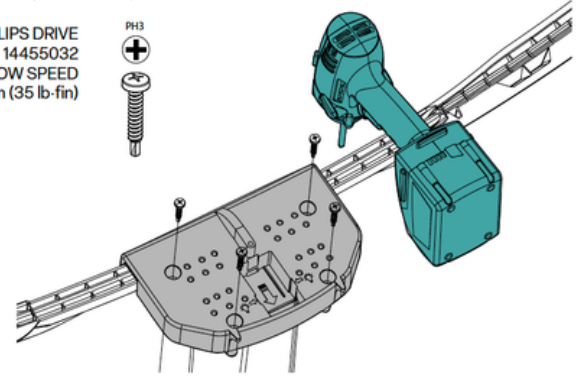

INSTALLING THE TOP PLATES - STRAIGHT SECTION

Insert the screw detail of the top plate inside the support pillar, making sure that the rail is inside the rear groove. Before screwing, make sure the plate rests flat on the pillar. Assemble one screw (14433700-ZINC) and one washer (14073852) on each side.

There are additional screwing provisions on the pillar and in the event of damage to the plate.

P3 - PHILLIPS DRIVE
P/N 14433700-ZINC
MAX TORQUE 3 N-m (27 in-lbf)
SCREW AT LOW SPEED



STEEL WASHER #12
P/N 14073852

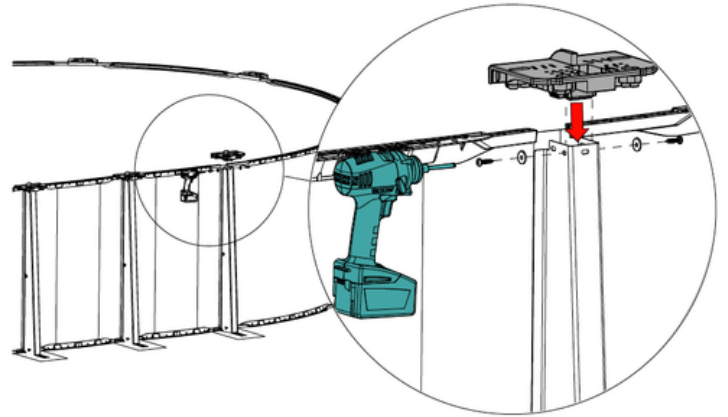

INSTALLING THE POST COVERS

STEP 1

Insert the post cover, aligning the top of it under the top plate (1) and pivot the bottom of the post cover towards the pool wall (2).

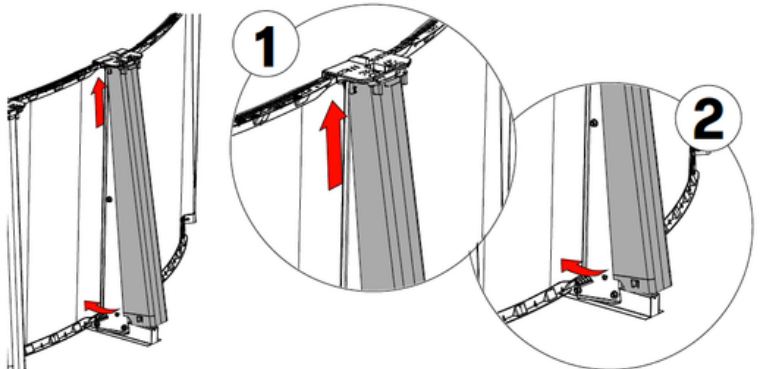

STEP 2

Align the upper holes in the post cover with the inner set of holes in the top plate.
Assemble 4x screws (14455032) per plate.

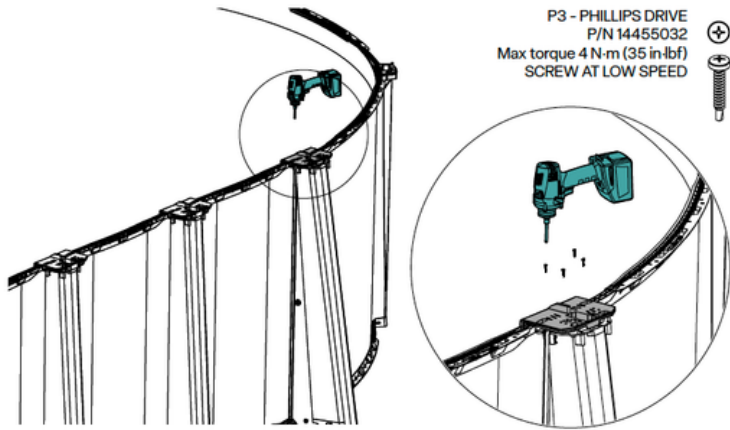

Make sure the oblong holes on the ledge are aligned with the screw holes on the top plate.

Use the corrugation (folds or wrinkles) of the wall to check the verticality of the uprights.

Make sure the uprights are straight before screwing the ledges in place.

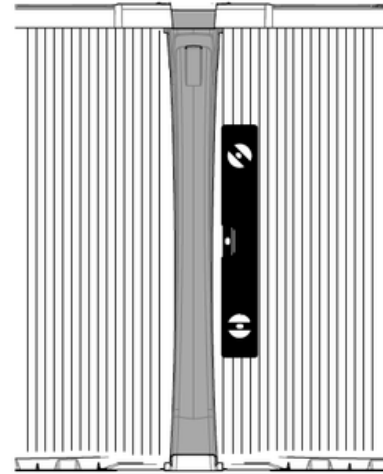

STEP 3

At the bottom of the posts, there is 1 hole on each side, assemble with the support pillar 1X screw (14433700-ZINC) and washer (14073852) on each side.

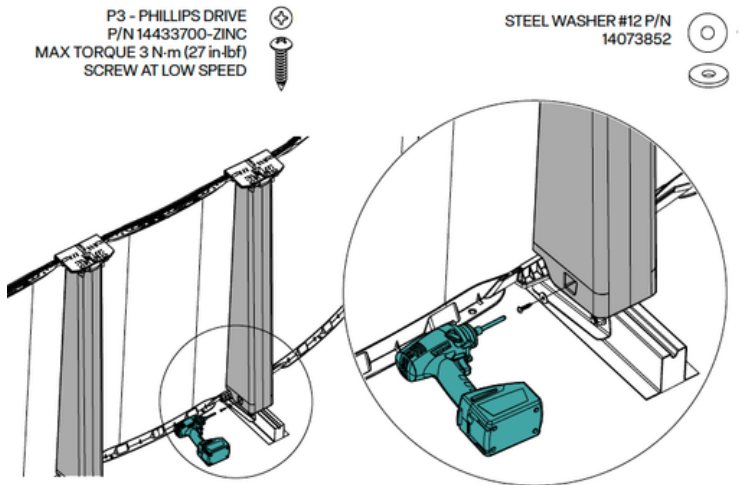

STEP 3

LEDGES POSITIONING

Push the ledge towards the outside of the pool until the edge touches the top plate.

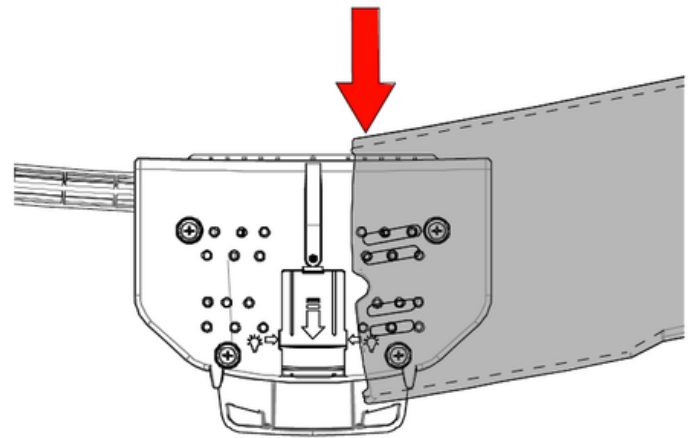

INSTALLING THE LEDGES

STEP 1

Position all ledge stones around the pool structure

STEP 2

Center the ledges on the top plates.

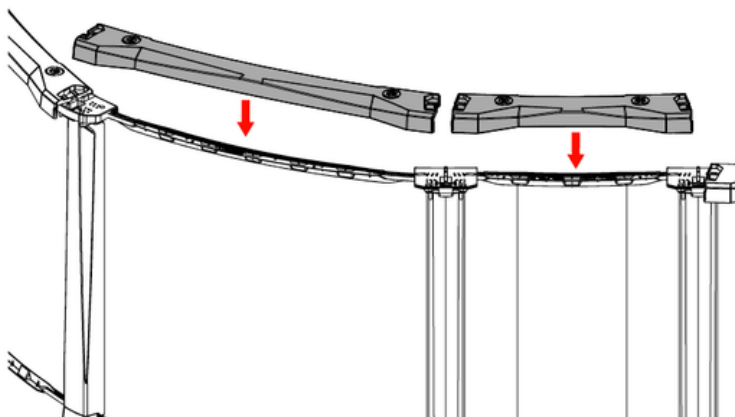

STEP 4

FIXING LEDGES

Screw on the ledge using 2 self-tapping screws on each side (14455110) (total of 4 per ledges). Use the oblong holes as far out as possible to screw the ledge. Several holes are available on the top plate to make the assembly. You can use the one that seems best located for your assembly.

P3 - PHILLIPS DRIVE
P/N 14455110
Max torque 4 N-m (35 lbf-in)
SCREW AT LOW SPEED

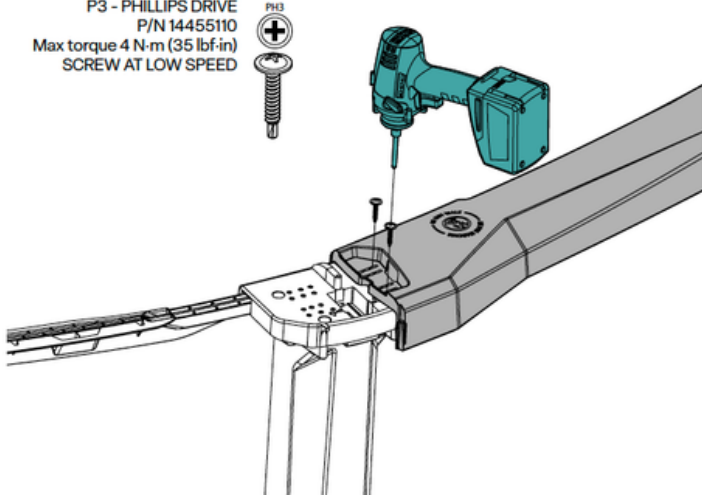

INSTALLING THE LEDGE COVERS

STEP 1

Pre-assemble the front and rear ledge cover by inserting them into each other in the detail provided, until they click into place.

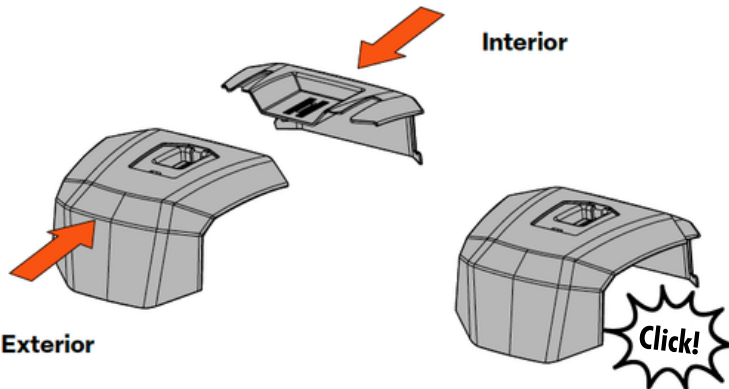

STEP 2

Insert the rear hook of the assembled covers under the inner edge of the ledge, then rotate it towards the outside of the pool, lowering it.

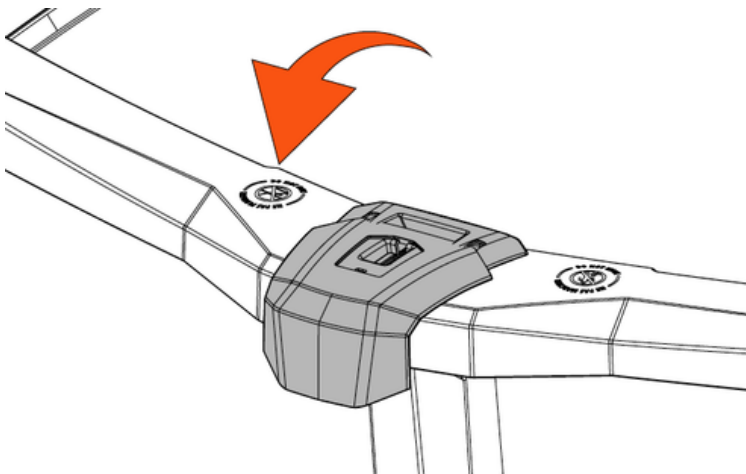

STEP 3

Hold the rear of the ledge cover and push on the front until they are firmly in place.

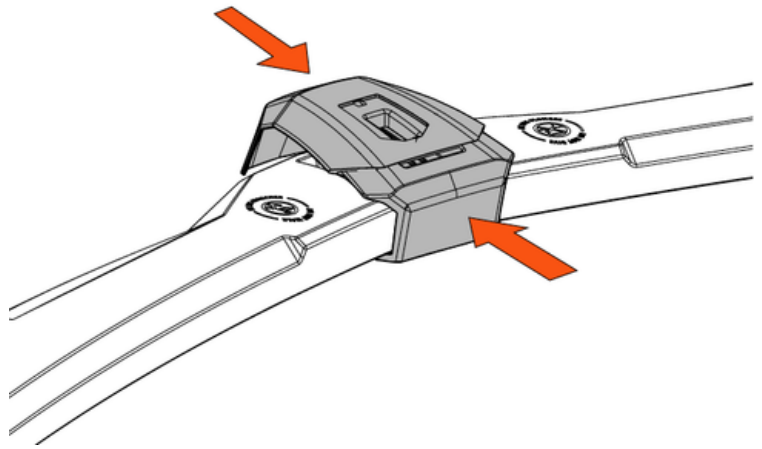

STEP 4

Align the slot in the cover with the central hole in the top plate. Screw the assembly in place using a screw (14455032).

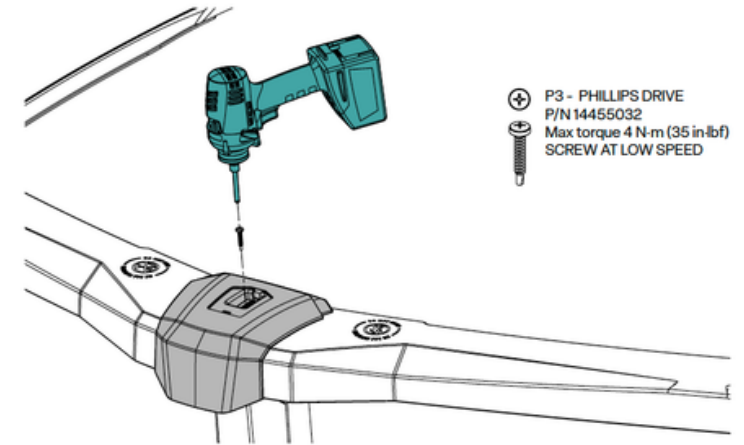

STEP 5

Install the ledge cover cap by pushing it until it clicks into place.

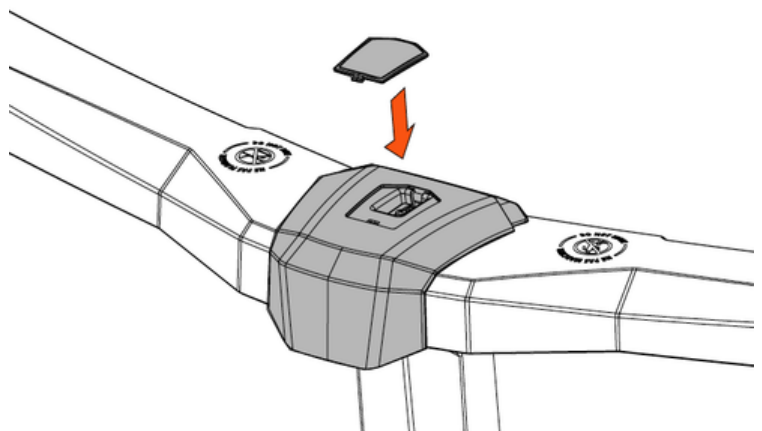

FIXING BOTTOM PLATES TO THE STRUCTURE

Fix 2 screws (14455032) in the rear detail on each side of the bottom plate to secure the entire structure. These fasteners will prevent the uprights and bottom plates from slipping out of place when the ground freezes and thaws.



The presence of hardware in the bottom plate is mandatory. They provide strength and stability when there are ground movements.

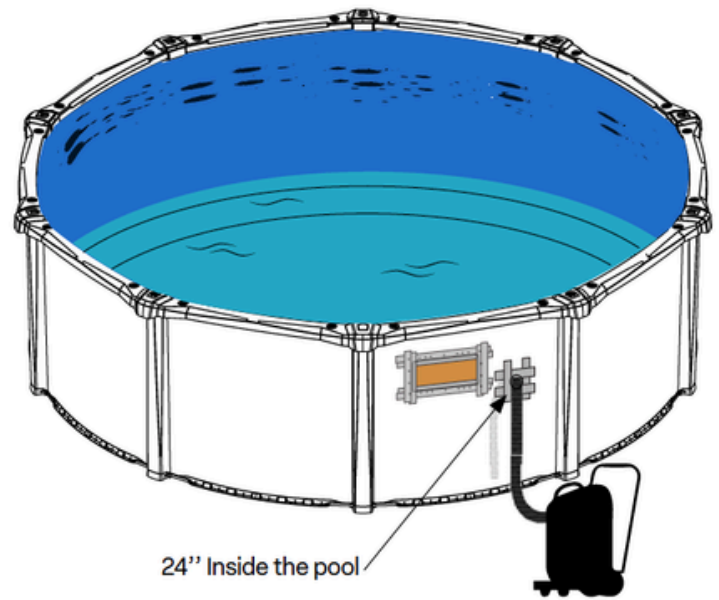
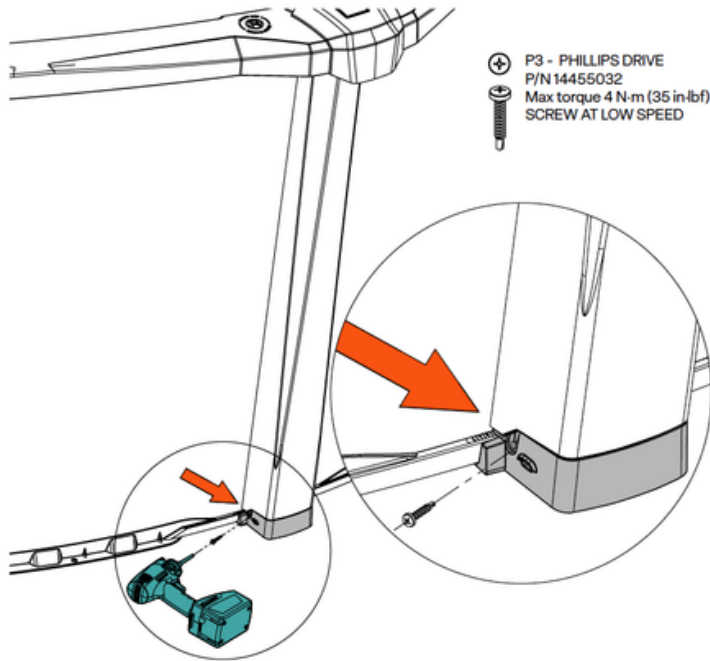

FILLING THE POOL

STEP 1

A vacuum cleaner is used to remove the air between the liner and the pool wall. By removing the air, the liner will stretch and stick to the walls of the pool. This operation will allow you to correct the surface of the liner to remove wrinkles.



Do not use an industrial vacuum cleaner of more than 5 HP, which could suck up the liner and damage it, or even puncture it.



Make sure that the end of the vacuum hose has no sharp edges that could damage the liner. Tape the edges of the nozzle if in doubt.

STEP 2

On the outside wall of the pool, seal the skimmer hole with a piece of cardboard and tape around the edge with grey "Duct Tape". Make sure you cover the rectangular section and the holes so that no air can seep through.

Insert the vacuum cleaner hose about 24" (60cm) into the water inlet hole from the outside. Make sure the hose is at least 6" (15cm) away from the cove to avoid moving it or suctioning it.

Fix and seal the vacuum hose to the outside of the pool wall using grey "Duct Tape". Be sure to seal the hose and the hole to prevent air from seeping in.

STEP 3

Start the vacuum cleaner. The liner will begin to stick to the walls. If there are any creases, it's time to stretch the liner to remove them.

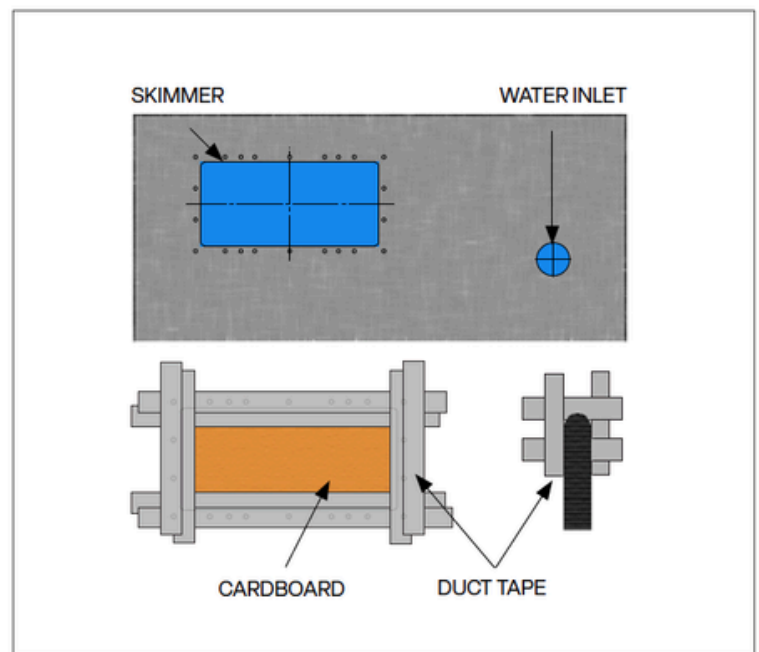

STEP 4

When you see that the liner is no longer moving under suction and there are no creases, start filling the pool with a hose while leaving the hoover running.

Throughout the filling process:

- Check the liner for creases. To prevent the liner from moving, smooth out any creases visible at the bottom of the pool before there is too much water in the pool. The slow flow of the hose will allow the liner to stretch and give you time to put it back in place if you see any creases.
- Inspect the structure regularly. Make sure the bottom rails stay in place and flat against the foundation. Make sure the wall stays in place in the rails and that no folds form in the wall when the weight of the water pulls on the liner. If the metal wall bends, stop filling immediately, examine and correct the problem with the structure.

STEP 5

When there is about 12" (30 cm) of water from the bottom of the pool, stop the vacuum cleaner, remove the hose from the water inlet hole and the cardboard from the skimmer

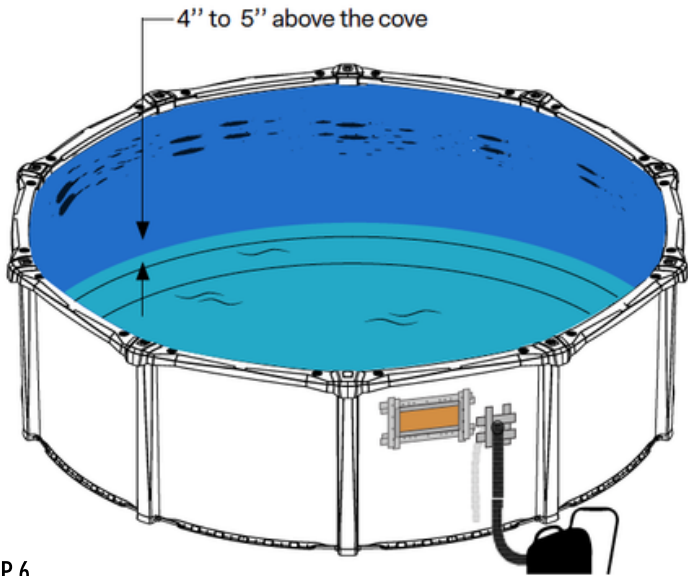

STEP 6

When the water reaches a level of 12" (30 cm) from the bottom, you can use a faster water flow.



To allow the pool to expand naturally, the flow rate when filling must not exceed 16 GPM. Do not make the foundation drain protection around the pool until it is completely filled with water.

STEP 7

When the water reaches a level of 24" (60 cm) from the bottom, the liner has stretched correctly. It's time to install the skimmer and water inlet. Follow the manufacturers' instructions for the installation of these accessories. It is very important to be meticulous when performing the installation of the skimmer and water inlet, as they could leak and corrode your pool wall.



A basic circulation and filtration system **MUST BE INSTALLED** on your pool.

STEP 8

The basic filtration system includes, as a minimum, in the order of installation:

- A skimmer
- A recirculation pump
- A filter
- A water inlet

Be sure to use and properly maintain the equipment in accordance with the recommendations of their respective manufacturers. Do not switch on the equipment at this stage. If the water level reaches 2" below the inlet hole and the above equipment is not installed, stop filling the pool and install your equipment.

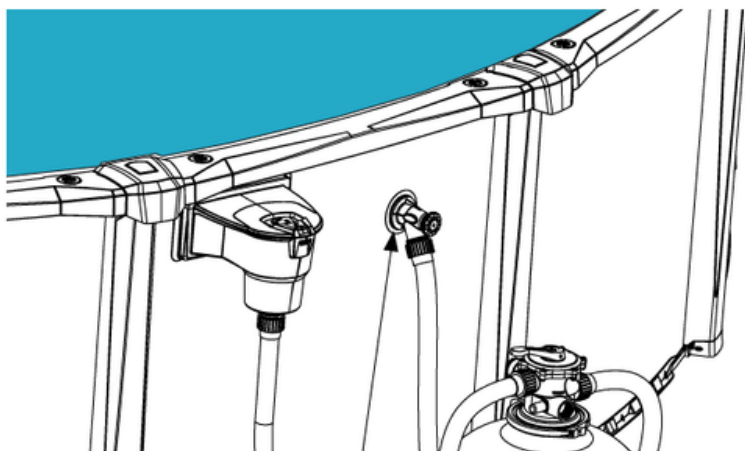

Make sure you comply with all local and State regulations when installing pool accessories. Elements allowing entry to the pool must be approved for user safety.

STEP 9

Once your filtration system is installed, fill the pool until the water reaches 1.5" to 2" from the top of the skimmer or until it reaches the 'Maximum' mark on the decorative plate of the skimmer.

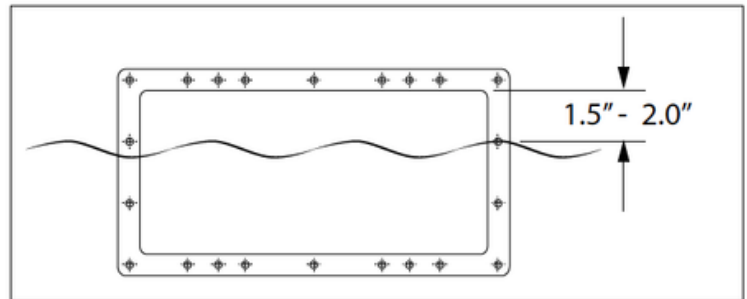

STEP 10

You can now switch on your circulation and filtration system. Make sure you use and maintain this equipment in accordance with the recommendations of their respective manufacturers.

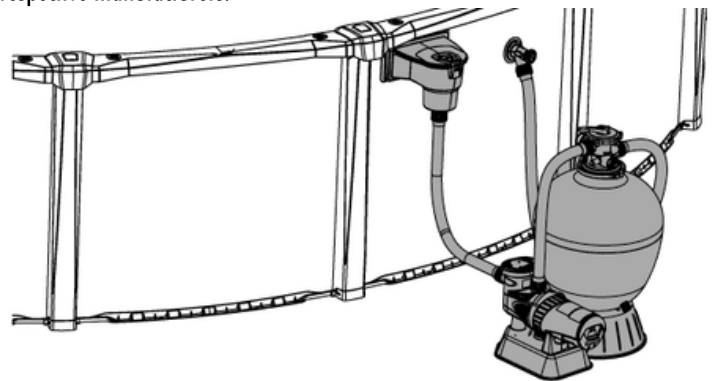

Never introduce chemicals into the pool through the skimmer. This will cause major problems for your filtration system and could damage it in the long term.

INSTALLING SAFETY STICKERS

Before using your pool, the first step is to affix the safety stickers. It is **STRICTLY FORBIDDEN** to remove these stickers. If the stickers supplied are not affixed and visible around your pool, you could be prosecuted in the event of an accident. Follow the information on the following pages to put them in the right place. You must not use your pool if the stickers are not affixed.



OWNERS AND INSTALLERS. Fit the warning stickers supplied, as shown in this manual. These stickers alert users to the dangers of jumping and diving and can prevent accidents.

INTERIOR STICKER

Place the small warning stickers on the liner above the water level and on the ledge opposite to the ladder so that they are visible to swimmers.

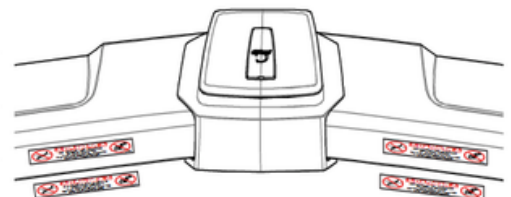

ENTRY STICKER

Install the large warning sticker on the wall at the entrance to the pool to ensure that everyone entering the pool is aware of the dangers.



FOUNDATION DRAINAGE PROTECTION

To protect the compacted foundation and prevent it from being drained, spread river rock or stone a minimum of 3/4" diameter all around your pool. A strip at least 10" wide and 2 to 3 inches thick. The top of the lower rails must remain visible.



Not doing this or using any other organic product such as soil, peat moss, turf, mulch or any other moisture-retaining substrate will accelerate the deterioration of the pool's components.

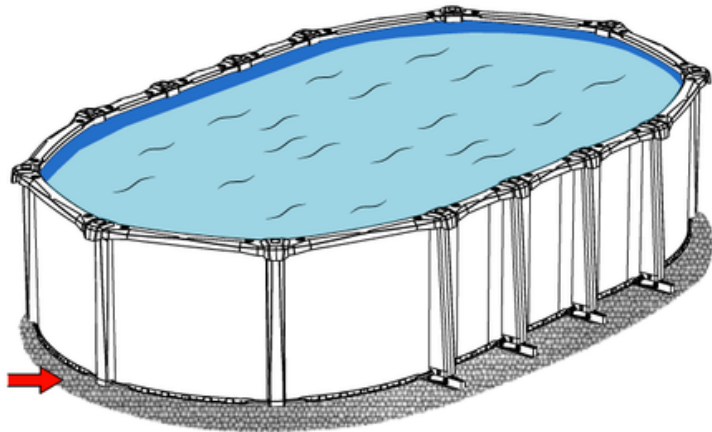

INSPECTION

The parts most likely to cause a problem with leaks are the skimmer and the water inlet. Regularly inspect the area around these two components to check that no water is leaking onto the pool wall. Carry out the necessary repairs to the skimmer and water inlet joints (or replace them) in order to stop these leakages, as they can cause corrosion and seriously damage the pool's sheet metal wall, causing it to eventually burst. This could cause serious damage to your property, that of your neighbors and put lives in danger.

Your pool liner should be inspected regularly for leaks. Water leaks can damage the wall of your pool, as the water contains corrosive products that will accelerate corrosion. If you detect leaks, **ACTION MUST BE TAKEN IMMEDIATELY**. You can easily repair minor liner damage using a patch kit available from your retailer.



Failure to carry out these inspections and repairs will invalidate the manufacturer's warranty.

WATER CHEMISTRY

Water chemistry plays an essential role in the good functioning of a swimming pool. Clean, balanced water is essential for the safety and well-being of pool users, as it can cause illness and infections. Unbalanced water will also lead to premature deterioration of pool components and equipment. That's why it needs to be assessed on a regular basis. A number of products are available to help you assess, treat and rebalance your water. See the table below for the values for balanced pool water.

It's important to remember that the filtration system and proper circulation of the water in the pool account for more than 50% of healthy water maintenance. It's therefore important to ensure that the water circulates well around the pool and to maintain the filtration system regularly to improve sanitation and reduce algae growth and other bacteria.

TABLE - RECOMMENDED WATER CHEMISTRY PARAMETERS

Parameters	Minimum	Target	Maximum
Temperature difference	+59°F (15°C)	-	+104°F (+40°C)
Salt concentration (Olio™)	3000 ppm	3300 ppm	4000 ppm
Cyanuric acid	30 ppm	30-50 ppm	100 ppm
pH	7.2	7.4 - 7.6	7.8
Free chlorine	1.0 ppm	2.0 - 3.0 ppm	3.0 ppm
Combined chlorine (Chloramines)	-	0 ppm	0.2 ppm
Total alkalinity	60 ppm	100-120 ppm	180 ppm
Calcium hardness	200 ppm	-	300 ppm
Total dissolved solids (TDS) (including salt)	-	-	1500 ppm
Metals (copper, iron, manganese)	-	NONE	-
Nitrate	-	NONE	-
Phosphate	-	NONE	-
Saturation index	-0.3	0.0 / +0.5	+0.5

- ppm = particle per million, ppb = particle per billion
- This series of pools is compatible with a salt chlorine generator; consult the owner's manual

Owner's Manual for ideal pool water salinity levels.



Pool water contains a number of products that are corrosive to the pool wall. It is important to check that there are no leaks in the liner. Any leaks will lead to long-term corrosion of the wall, which will reduce its strength. The wall could break and cause major damage to your property and/or your neighbors and could also cause serious injury to people near or in the pool.

REGULAR CLEANING

Keep the walls and plastic structure clean. Always clean any chemical deposits that may appear on the pool's external surfaces. We recommend cleaning these surfaces (structure and walls) at least once a year with a degreasing cleaning product that does not contain bleach. It is important to clean the liner, where deposits can form when the water evaporates. It is also recommended that any algae deposits on walls or equipment immersed in water should be checked and cleaned regularly.

WINTERIZING THE POOL

In regions where freezing temperatures occur, it is common practice to close an outdoors swimming pool during the winter. This is known as winterization. This step should be considered as soon as the pool is installed. All our pools have been designed to remain assembled outside during the winter. However, the following instructions should be followed when winterizing your pool. Proper winterizing should only take a few hours and will make spring opening much easier.



Failure to follow winterization instructions may cause irreparable damage to the pool and/or harm to your home or surrounding structures.

As the water temperature cools, there is less and less need to add chemicals. It is, however, necessary to check the water's chemical chemicals periodically in order to keep the water clean and within the recommended values. Failure to comply with these values could cause the pool liner to degrade and shorten its lifespan.

INSPECTION

STEP 1

Before closing the pool each year, check the water chemicals (ph, alkalinity, chlorine, etc.) Water with unadjusted chemistry will damage the liner and could cause corrosion on the pool wall.

STEP 2

Check that there are no leaks in the liner. To be sure, for a week in early September, check that the water level does not drop. If the water level does drop, it means there is a leak. Immediately repair the holes in the liner using repair kits that can be purchased from your pool specialist. Check that there are no leaks around the skimmer or water return. If a leak is found around these elements, action must be taken immediately to rectify the situation. Check that the liner is still securely fastened to the top of the sheet metal wall.



Water leaking from the liner during the winter can cause significant soil movement when the water freezes under the pool. This can cause major damage to your pool.

STEP 3

Check the structure of the pool for scratches and/or corrosion on the wall. If necessary, repair them using an anti-corrosion enameling product. Scrub the rusted surface with a wire brush, make sure all the rust is removed, apply the anti-corrosion product and paint the surface to match the color of the wall. Also check that the wall joint (joining the 2 ends of the pool wall) is solid and that the screws are tight.

WATER PREPARATION

STEP 1

Keep your pool water within acceptable parameters in the weeks leading up to its closure.

STEP 2

Clean the bottom of your pool of any dirt before lowering the water level.

STEP 3

Lower the water level to between 6" and 20" below the level of the water return, depending on the climate of your region. Check with your Cool Pool for recommendations on the water level to maintain when winterizing.

For regions where there is frost, the pool must be emptied between 15" and 20" below the water inlet.

Do not empty the pool completely. This operation could cause your liner to move. It would also lighten your pool, which could be blown away in strong winds and cause major damage to your property or that of your neighbor. It could also cause serious injury or even death.

STEP 4

Use a set of pool closure products available from Cool Pool. Using this kit will considerably reduce the time and quantity of chemicals required when you restart your pool each spring.



It is advisable to check the water level in the autumn after winterization before the water freezes. If the water level rises drastically, it is advisable to re-drain the water to bring it back down to the recommended level.



It is important never to lower the water in the pool if it has frozen and forms a block of ice, as this can cause considerable damage to the liner and the pool.

WINTERIZING OF THE FILTRATION AND RECIRCULATION SYSTEM

STEP 1

Disconnect all hoses from the filtration system: pump, filter, skimmer, valves, water return, etc.

STEP 2

Drain the pump, filter and water heater and winterize them according to the recommendations in their respective manuals.

STEP 3

If you have water features, it is important to winterize them according to the recommendations in your manuals.

STEP 4

The winterization of the water return and the skimmer is different according to the climate of the region in which you are located.

For regions where there is frost: It is imperative never to obstruct the return water and skimmer openings. Make sure that the water entering the water return drains away from the pool at all times. Regularly check that the openings are not blocked by ice.

STEP 5

If your pool is equipped with a bottom drain (for regions where frost is present), it is essential to use antifreeze specially designed for swimming pools to prevent the pipe from freezing and rupturing.

Make sure that the water level in the pool is correctly lowered, then remove the hose that connects your filtration system to your bottom drain. Make sure that the end of the hose is above the water level at all times (so that the pool does not drain through it). Empty the antifreeze slowly into the hose until you see it coming out of the bottom drain. Make sure the hose stays above the level of the water inlet throughout the winter by securing it to the ledge.

STEP 6

Store all components; pump, ladder and any other product that needs to be stored in a well-tempered place protected from the elements.



Do not turn off the filtration system until the pool is completely closed, to keep the water healthy until it is winterized.



Closing the pool too late could allow the water in the pipes, skimmer and water inlet to freeze and damage the filtration system components and the pool.

USING A WINTER COVER

After winterization, install a quality Unrippable™ Winter Cover to protect your Cool Pool from snow ice & debris damage.

RECOMMENDATIONS AND MAINTENANCE DURING WINTER

1. Check that there is no obstruction in the water inlet orifice and that the water can drain away from the pool.
2. Check that water, snow and ice do not accumulate in the skimmer during the freezing period. It is important to check regularly that these are free of build-up at all times. This could damage the skimmer and cause the pool wall to collapse when the thaw comes.
3. The pool is designed to support the volume of water contained in it, and therefore to work horizontally. Make sure you remove any snow that accumulates on the structure (the ledges). Do not allow more than 12" of snow to accumulate on the pool ledges at any given time.
4. Do not hit a pool containing frozen water, as this will damage it.
5. Do not climb inside a frozen pool. This could cause the ice to shift and rub against the liner, breaking it and seriously damaging the pool.

SPRING OPENING

When the outside temperature reaches 50°F and the pool water has completely thawed, it's time to restart your pool's filtration system.

STEP 1

Remove the winter cover from the pool, remove any water that may have accumulated on the cover over the winter and any other dirt and leaves.

STEP 2

Reposition your filtration system and reconnect the pipes linking it to the skimmer and the water inlet.

STEP 3

Fill the pool until the water level is in the middle of the skimmer. Inspect your pool for visible corrosion or leaks. Pay particular attention to the areas around the skimmer and the water inlet. If necessary, correct the problem immediately.

STEP 4

Clean the bottom of the pool by vacuuming up any leaves or dirt. Put the sand filter in the "DRAIN" position to remove the dirt from the pool without going through the filter. This operation in "Drain" mode will extend the time before you need to "backwash" the sand in your filter.

Do not empty your pool completely to clean the water unless you have to, as this could cause creases in your liner. If you absolutely must, do not leave the pool empty for a long period. A liner exposed to the sun could shrink and dry out. The structure could also move in strong winds, making it very dangerous.

STEP 5

Adjust the chemicals of your pool water.

Make sure that the skimmer and water inlet are not leaking. Such a leak could corrode the wall of the pool and seriously damage its structure.

AVAILABILITY OF REPLACEMENT PARTS

Replacement parts are available from your Cool Pool at www.freetimefun.com



BY



1830 E. Fabyan Pkwy
Batavia, IL 60510
1-888-620-6088
www.freetimefun.com

ROUND SECTION

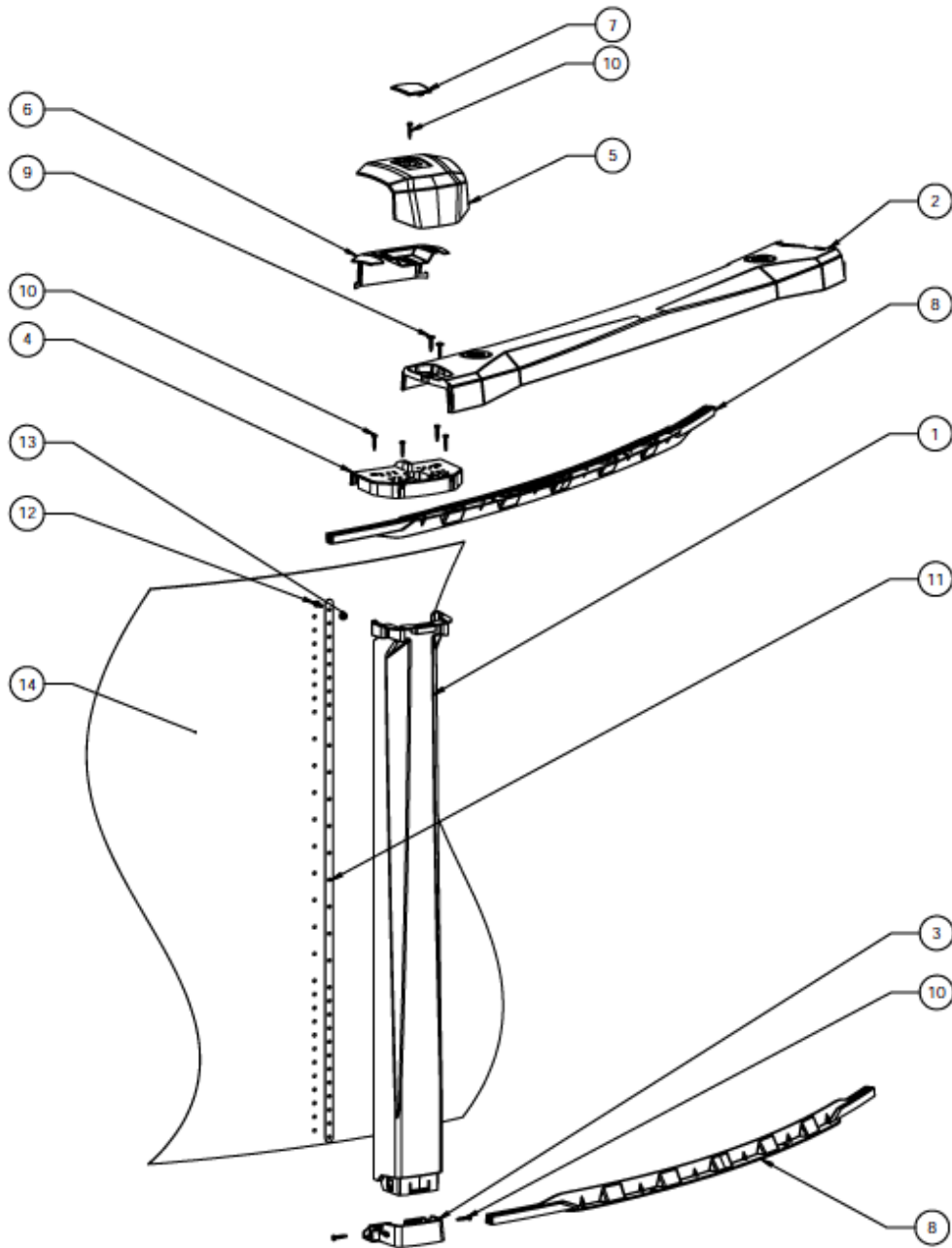
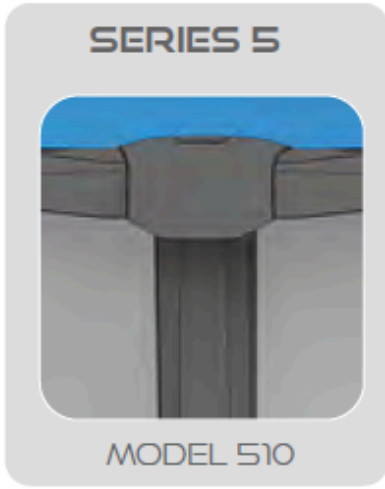

METALLIC STRAIGHT SECTION PARTS

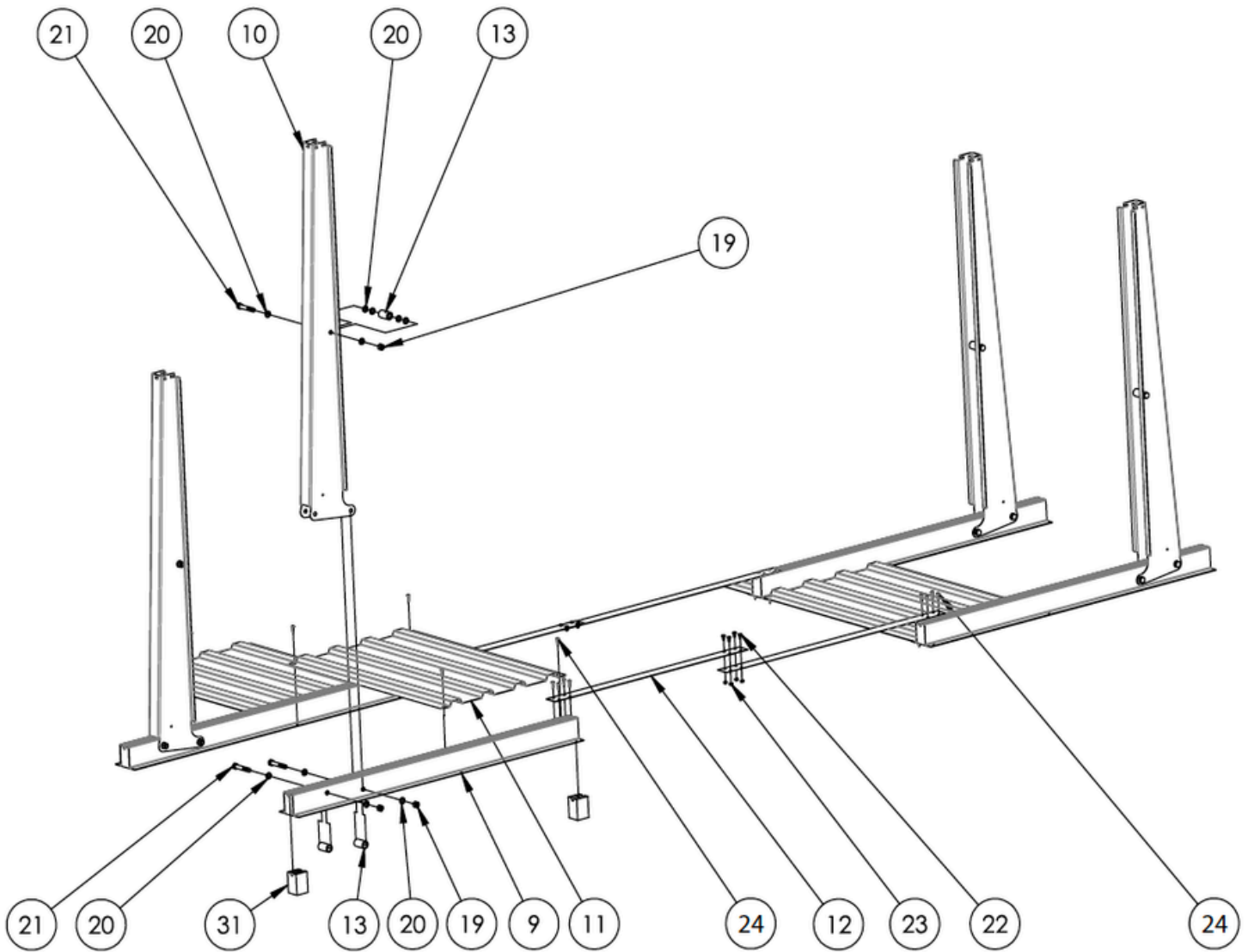

STRAIGHT SECTION

SERIES 5



MODEL 510

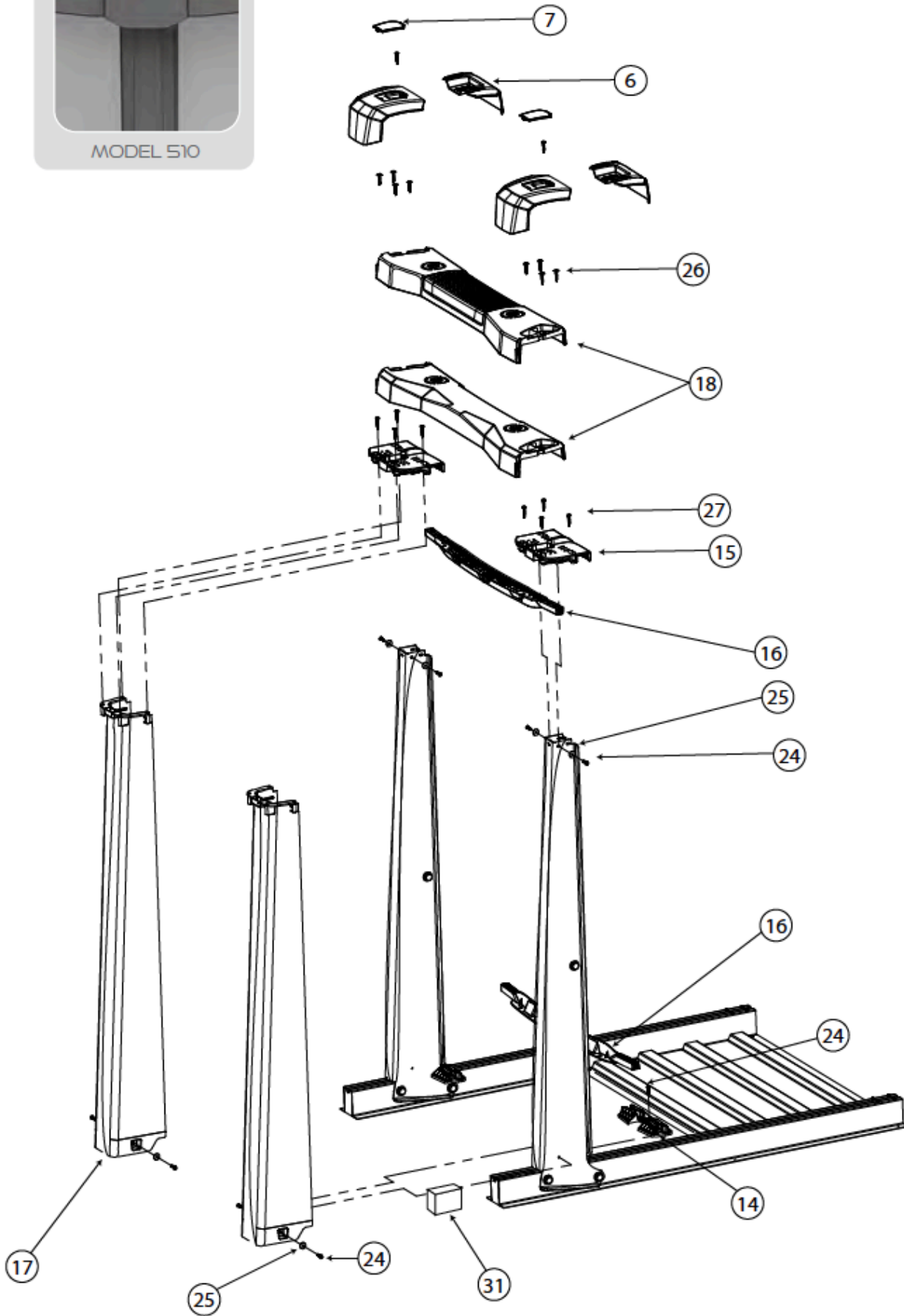

ITEM #	BLACK	DESCRIPTION	QUANTITY PER SIZE								
			12X15	12X18	12x21	12x24	15x21	15x24	15x30	18x33	18x39
S500 SERIES PARTS - ROUND SECTION											
1	45123006	S500 UPRIGHT 52"	6	6	6	6	8	8	8	10	10
	45124006	S500 UPRIGHT 54"	6	6	6	6	8	8	8	10	10
2	45234006	S500 TOP LEDGE	8	8	8	8	10	10	10	12	12
3	46025706	BOTTOM PLATE	6	6	6	6	8	8	8	10	10
4	46077506	TOP PLATE	6	6	6	6	8	8	8	10	10
5-6	45389006R1	S500 TOP LEDGE COVER (FRONT & REAR COVER)	10	12	14	16	14	16	20	22	26
7	45367006	S500 TOP LEDGE COVER CAP	10	12	14	16	14	16	20	22	26
S510 SERIES PARTS - ROUND SECTION											
1	45151006	S510 UPRIGHTS 52"	6	6	6	6	8	8	8	10	10
	45153006	S510 UPRIGHT OR 54"	6	6	6	6	8	8	8	10	10
2	45263206	S510 TOP LEDGE	8	8	8	8	10	10	10	12	12
3	46025706	BOTTOM PLATE	6	6	6	6	8	8	8	10	10
4	46077506	TOP PLATE	6	6	6	6	8	8	8	10	10
5-6	45387006R1	S510 TOP LEDGE COVER (FRONT & REAR COVER)	10	12	14	16	14	16	20	22	26
7	45384006	S510 TOP LEDGE COVER CAP	10	12	14	16	14	16	20	22	26
COMMON PARTS											
8	46026315	ROUND SECTION RAIL 15'	16	16	16	16	20	20	20	24	24
9	46025030	STEEL FOOTBEAM	4	6	8	10	6	8	12	12	16
10	46025031	STEEL BUTTRESS FREE POST 52"	4	6	8	10	6	8	12	12	16
	46025600	STEEL BUTTRESS FREE POST 54"	4	6	8	10	6	8	12	12	16
11	46025003	STEEL PRESSURE PLATE	2	4	6	8	4	6	10	10	14
12	46025007	STEEL TIE STRAP 35"	2	3	4	5	-	-	-	-	-
	46025006	STEEL TIE STRAP 40"	2	3	4	5	-	-	-	6	8
	46025005	STEEL TIE STRAP 55"	-	-	-	-	6	8	12	12	16
13	46025010	MANCHON	12	18	24	30	18	24	36	36	48
14	46024006	STRAIGHT SECTION BOTTOM PLATE	4	6	8	10	6	8	12	12	16
15	46077306	STRAIGHT SECTION TOP PLATE	4	6	8	10	6	8	12	12	16
16	46026206	STRAIGHT SECTION RAIL	4	8	12	16	8	12	20	20	28
S500 SERIES PARTS - STRAIGHT SECTION											
17	45278006	SUNLAB OVAL POST COVER 52"	4	6	8	10	6	8	12	12	16
	45278006	SUNLAB OVAL POST COVER 54"	4	6	8	10	6	8	12	12	16
18	45135006	S500 STRAIGHT SECTION TOP LEDGE	2	4	6	8	4	6	10	10	14
S510 SERIES PARTS - STRAIGHT SECTION											
17	45278006	SUNLAB OVAL POST COVER 52"	4	6	8	10	6	8	12	12	16
	45278006	SUNLAB OVAL POST COVER 54"	4	6	8	10	6	8	12	12	16
18	45176006	S510 STRAIGHT SECTION TOP LEDGE	2	4	6	8	4	6	10	10	14
HARDWARE											
19	14455045	1/2"-20-2B HEX NUT	12	18	24	30	18	24	36	36	48
20	14455095	1/2" FLAT WASHER	40	60	80	100	60	80	120	120	160
21	14455035	1/2"-20 X 3" HEX SCREW PARTIALLY THREADED	12	18	24	30	18	24	36	36	48
22	14455075	1/4"-20 X 1/2" HEX SCREW	8	12	16	20	12	16	24	48	64
23	14455085	1/4"-20 - 2B HEX NUT	8	12	16	20	12	16	24	48	64
24	14433700-ZINC	PAN-HEAD PHILLIPS SCREWS FOR METALS # 12-11 X 1"	48	76	104	132	76	104	160	160	216
25	14073852	# 12 FLAT WASHER	16	24	32	40	24	32	48	48	64
26	14455110	SELF-TAPPING SCREW WITH WASHER # 12 X 1-1/4"	40	48	56	64	56	64	80	88	104
27	14455032	SELF-DRILLING SCREW # 12 X 1-1/4"	58	66	74	82	80	88	104	118	134
28	02581536	WALLBRACKET 52"	2	2	2	2	2	2	2	2	2
	02581541	WALLBRACKET 54"	2	2	2	2	2	2	2	2	2
29	14172209R30-ZINC	PAN SCREW 1/4"-20 X 3/4" (52" WALL)	30	30	30	30	30	30	30	30	30
	14172209R32-ZINC	PAN SCREW 1/4"-20 X 3/4" (54" WALL)	32	32	32	32	32	32	32	32	32
30	14072620R30-ZINC	HEXAGONAL FLANGE NUT (52" WALL)	30	30	30	30	30	30	30	30	30
	14072620R32-ZINC	HEXAGONAL FLANGE NUT (54" WALL)	32	32	32	32	32	32	32	32	32
31	46025015	BLOCK OF EXPANDED POLYSTYRENE	8	12	16	20	12	16	24	24	32

REPLACEMENT PARTS

52" STEEL POOL WALL				
ITEM #	ST. GERMAIN	BELLINI	SIZE	QUANTITY
32	9710021215	9750031215	12 X 15	1
	9710021218	9750031218	12 X 18	1
	9710021221	9750031221	12 X 21	1
	9710021224	9750031224	12 X 24	1
	9710021521	9750031521	15 X 21	1
	9710021524	9750031524	15 X 24	1
	9710021530	9750031530	15 X 30	1
	9710021833	9750031833	18 X 33	1
	9710021839	975031839	18 X 39	1
54" ALUMINIUM POOL WALL				
ITEM #	ST. GERMAIN		SIZE	QUANTITY
32	9710521215		12 X 15	1
	9710521218		12 X 18	1
	9710521221		12 X 21	1
	9710521224		12 X 24	1
	9710521521		15 X 21	1
	9710521524		15 X 24	1
	9710521530		15 X 30	1
	9710521833		18 X 33	1
	9710521839		18 X 39	1